

1. 机壳、外装分组件/Machine frame & cover components

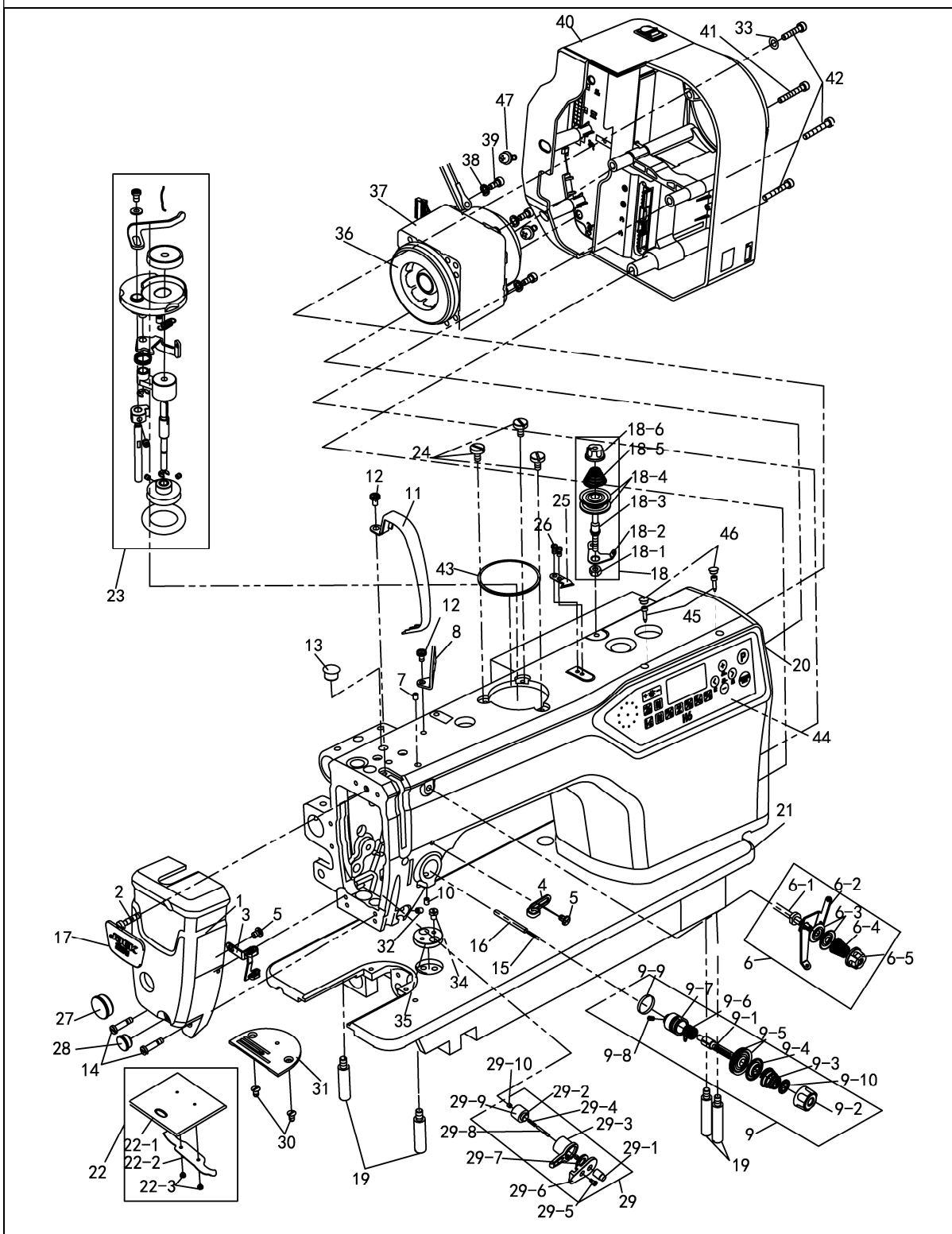

1.机壳、外装分组件/Machine frame & cover components								
序号 NO.	公司件号 Part NO.	名称 PartName	零件描述 Description	数量 Number				
				-3	XB	ZD	ST	H6+
1	930000500	面板	Panel	1	1	1	1	1
2	201511025	面板螺钉 SM11/64×40	Panel screw SM11/64×40	1	1	1	1	1
3	13813005	面板线勾	Panel thread guide	1	1	1	1	1
4	10113004	右线钩	Panel thread guide (right)	1	1	1	1	1
5	101511007	螺钉 SM11/64×40×6	Screw SM11/64×40×6	2	2	2	2	2
6	1411300400	小夹线器组件	Small thread tension assay	1	1	1	1	1
6-1	13812066	过线板	Thread tension guide plate	1	1	1	1	1
6-2	13810008	小夹线器螺柱	Thread tension bolt	1	1	1	1	1
6-3	11212004	小夹线板	Thread tension disk	2	2	2	2	2
6-4	11227001	小夹线弹簧	Thread tension spring	1	1	1	1	1
6-5	138516019	小夹线器螺母	Thread tension nut	1	1	1	1	1
7	113514002	小夹线固定螺钉	Set screw	1	1	1	1	1
8	13512004	三孔线勾	3-hole thread guide	1	1	1	1	1
9	11471300100	夹线组件	Thread tension assay	1	1	1	1	1
9-1	1147NS30001	夹线螺钉	Thread tension Screw	1	1	1	1	1
9-2	141516013	夹线螺母	Thread tension nut	1	1	1	1	1
9-3	14227024	夹线弹簧	Thread tension spring	1	1	1	1	1
9-4	10112006	松线板	Tension releasing board	1	1	1	1	1
9-5	14112015	夹线板	Thread tension disk	2	2	2	2	2
9-6	114727001	挑线簧	Take-up spring	1	1	1	1	1
9-7	13513006	夹线调节座	Thread tension retainer	1	1	1	1	1
9-8	135515002	夹线调节座螺钉	Screw	1	1	1	1	1
9-9	001050	O 型圈	O ring 14.5x1.5	1	1	1	1	1
9-10	10112007	夹线螺母止动板	Thread tension nut locking plate	1	1	1	1	1
10	136514002	螺钉 SM15/64×28	Screw SM15/64×28	1	1	1	1	1
11	14712018	挑线杆防护罩	Thread tade-up lever cover	1	1	1	1	1
12	101511004	螺钉 SM3/16X28 X7	Screw SM3/16X28 X7	2	2	2	2	2
13	10122005	挑线连杆销螺孔塞	Take-up link pin screw plug	1	1	1	1	1
14	135511047	面板螺钉 SM11/64×40	Panel screw SM11/64×40	2	2	2	2	2
15	14726002	松线钉	Thread release pin	1	1	1	1	1
16	13613002	松线棒	Thread release bar	1	1	1	1	1
17	115037001	A5E-0141 商标牌	A5E-0141 trademark	1	1	1	1	1
18	1411300600	绕线夹线器	Bobbin winder thread tension	1	1	1	1	1
18-1	114516001	螺母 SM11/64×40	Nut SM11/64×40	1	1	1	1	1
18-2	11413022	夹线过线板	Thread tension guide plate	1	1	1	1	1
18-3	13601006	夹线螺钉	Screw	1	1	1	1	1
18-4	10112005	夹线板	Thread tension disk	2	2	2	2	2
18-5	11427006	小夹线弹簧	Spring	1	1	1	1	1
18-6	141516019	夹线螺母	Thread tension nut	1	1	1	1	1
19	101512001	底板支柱	Base plate pillar	4	4	4	4	4
20	910000165	H6 机壳	H6 frame	1	1	1	1	1
21	100767	底板	Base plate	1	1	1	1	1
22-1	13515002	推板	Slide plate	1	1	1	1	1
22-2	13512007	推板簧	Slide plate spring	1	1	1	1	1
22-3	101511019	螺钉 SM3/32×56 L=2	Screw SM3/32×56 L=2	2	2	2	2	2

1.机壳、外装分组件/Machine frame & cover components

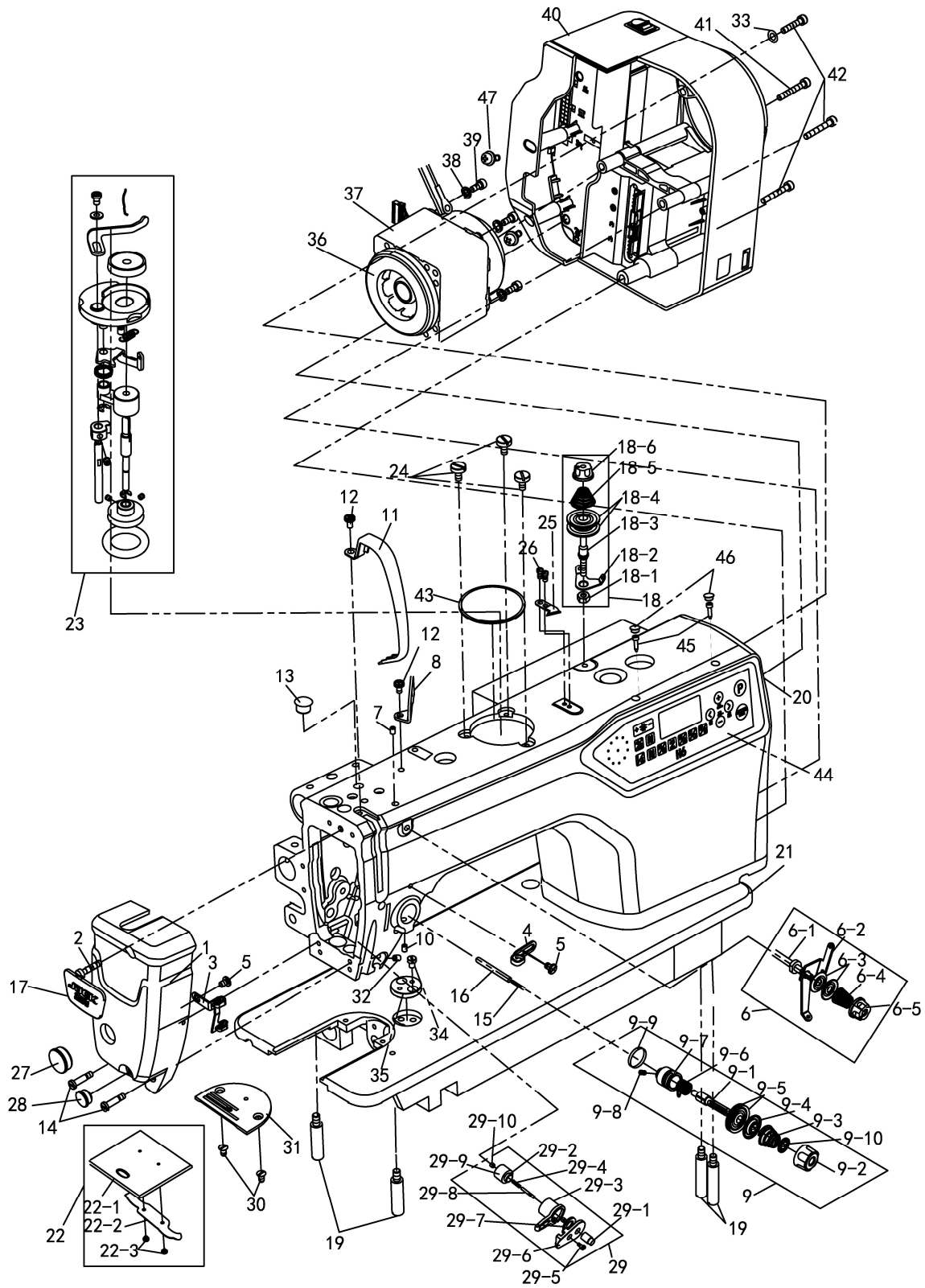

1.机壳、外装分组件/Machine frame & cover components

序号 NO.	公司件号 Part NO.	名称 PartName	零件描述 Description	数量 Number				
				-3	XB	ZD	ST	H6+
23	1361300800	绕线夹线器	Bobbin winder thread tension	1	1	1	1	1
24	114511003	开槽圆柱头螺钉	Screw	1	1	1	1	1
25	11419001	切线刀	Thread cutter	1	1	1	1	1
26	114511015	螺钉 SM9/64×40 L=6	Screw SM9/64×40 L=6	1	1	1	1	1
27	13522001	面板橡皮塞 (φ19)	Rubber plug(φ19)	1	1	1	1	1
28	13522002	面板橡皮塞 (φ11.8)	Rubber plug(φ11.8)	1	1	1	1	1
29	1363001000	电子夹线组件	Nest less e-device	1	1	1	1	1
29-1	11302025	夹线 φ6 芯子	Peg	1	1	1	1	1
29-2	11303035	夹线垫片铜套	Copper sheathing	1	1	1	1	1
29-3	13813031	夹线电磁铁外壳	Hull	1	1	1	1	1
29-4	11327021	弹簧	Spring	1	1	1	1	1
29-5	113520006	内六角花型轴位螺钉 M2	Screw	1	1	1	1	1
29-6	13813030	夹线盖板	Blind flange	1	1	1	1	1
29-7	11328030	夹线垫片	Washer	1	1	1	1	1
29-8	11302026	夹线不锈钢芯子	Peg	1	1	1	1	1
29-9	1383002700	电磁铁线圈	Magnet coil	1	1	1	1	1
29-10	11303036	铜套	Copper sheathing	1	1	1	1	1
30	104517002	螺钉 SM11/64×40 L=5	Screw SM11/64×40 L=5	2	2	2	2	2
31	13515001	针板	Needle plate	1		1		1
	13515004	针板	Needle plate				1	
	13515005	针板	Needle plate		1			
32	113514020	下轴后套螺钉	Screw	1	1	1	1	1
33	W01009	平垫圈	Washer 5	1	1	1	1	1
34	101511025	螺钉 SM11/64×40×7	Screw SM11/64×40×7	2	2	2	2	2
35	13812111	卷边器座	Beader pedestal	1	1	1	1	1
36	13811060	电机绝缘防护罩	Motor insulation shield	1	1	1	1	1
37	114733011	光电伺服电机	Motor	1	1	1	1	1
38	W02004	弹簧垫圈	Spring washer	4	4	4	4	4
39		螺钉 M5×70	Screw M5×70	4	4	4	4	4
40	11473301000	功能型电控	Machine electric control	1	1	1	1	
	11473300500	功能型电控(物联网)	Machine electric control					1
41	114513001	螺钉 M5×20	Screw M5×20	1	1	1	1	1
42	S05901	螺钉 M5×35	Screw M5×35	3	3	3	3	1
43	11422062	密封垫	Gland	1	1	1	1	1
44	11473000700	一体机电控面板组件	Control panel	1	1	1	1	1
45	138S05001	操作面板螺钉	Screw M3 L=12	2	2	2	2	2
46	13822001	操作屏孔塞	Rubber plug	2	2	2	2	2
47	421S11008	螺钉 M4×10	Screw M4×10	2	2	2	2	2

2. 上轴挑线分组件/Main shaft & thread take-up components

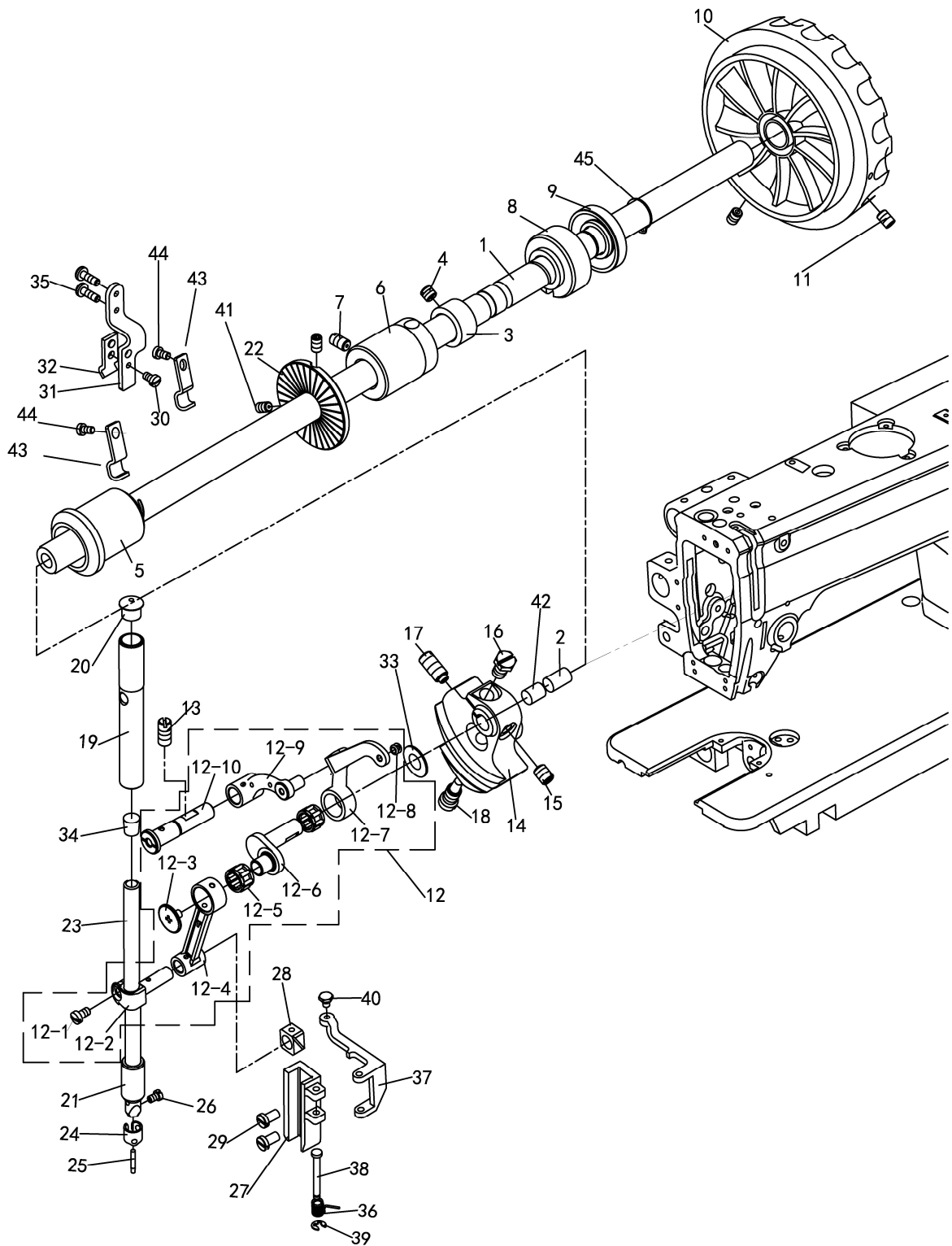

2.上轴挑线分组件/Main shaft & thread take-up components

序号 NO.	公司件号 Part NO.	名称 PartName	零件描述 Description	数量 Number				
				-3	XB	ZD	ST	H6+
1	114702004	上轴	Main shaft	1	1	1	1	1
2	10122012	上轴橡皮塞	Rubber plug	1	1	1	1	1
3	10108003	上轴紧圈	Shaft washer	1	1	1	1	1
4	101515002	螺钉 SM1/4×40×6	Screw SM1/4×40×6	2	2	2	2	2
5	13603023	上轴前轴套	Main shaft bushing front	1	1	1	1	1
6	13503017	上轴中轴套	Main shaft bushing middle	1	1	1	1	1
7	135515006	螺钉 SM15/64×28	Screw SM15/64×28	1	1	1	1	1
8	114703004	上轴后轴套	Main shaft bushing back	1	1	1	1	1
9	13522010	上轴后轴套油封组件	Bushing back oil seal assy	1	1	1	1	1
10	304714	主动轮	Capstan	1	1	1	1	1
11	S10009	主动轮螺钉 M6×8	Capstan screw M6×8	2	2	2	2	2
12	1353800200	挑线杆组件	Thread take-up assy	1	1	1	1	1
12-1	101511005	螺钉 SM11/64×40×8	Screw SM11/64×40×8	1	1	1	1	1
12-2	13505002	针杆接头	Needle bar connection	1	1	1	1	1
12-3	101517001	挑线曲柄螺钉 (左旋)	Screw	1	1	1	1	1
12-4	13505003	针杆连杆	Needle bar connecting rod	1	1	1	1	1
12-5	10124001	挑线杆滚针轴承	Needle bearing	1	1	1	1	1
12-6	13504002	挑线杆曲柄	Thread take-up crank	1	1	1	1	1
12-7	13538004	挑线杆	Thread take-up rod	1	1	1	1	1
12-8	13538003	挑线杆衬套	Thread take-up bushing	1	1	1	1	1
12-9	13538002	挑线连杆	Thread take-up connecting rod	1	1	1	1	1
12-10	13502003	挑线连杆铰链销	Pin	1	1	1	1	1
13	135515009	螺钉 SM15/64×28	Screw SM15/64×28	1	1	1	1	1
14	13504001	针杆曲柄	Needle bar crank	1	1	1	1	1
15	101515007	螺钉 SM1/4×40×8	Screw SM1/4×40×8	1	1	1	1	1
16	135512001	螺钉 SM1/4×40	Screw SM1/4×40	1	1	1	1	1
17	101515004	螺钉 SM9/32×28×16	Screw SM9/32×28×16	1	1	1	1	1
18	135511002	螺钉 SM9/32×28	Screw SM9/32×28	1	1	1	1	1
19	14703006	针杆上衬套	Needle bar upper bushing	1	1	1	1	1
20	10122013	针杆上衬套橡皮塞	Upper bushing rubber plug	1	1	1	1	1
21	13503007	针杆下衬套	Needle bar lower bushing	1	1	1	1	1
22	14735001	驱动轮	BTW-DRIVING-WHEEL	1	1	1	1	1
23	13602002	针杆	Needle bar	1	1	1	1	1
24	13513011	针杆过线环	Needle bar thread ring	1	1	1	1	1
25	13517001	机针(DP×17 23#)	Needle(DP×17 23#)	1		1		1
	13517003	机针(DP×17 22#)	Needle(DP×17 22#)		1			
	11617002	机针(DP×5 14#)	Needle(DP×5 14#)				1	
26	101511006	螺钉 SM1/8×44 L=4.5	Screw SM1/8×44 L=4.5	1	1	1	1	1
27	13609001	滑块槽	Slider trough	1	1	1	1	1
28	11409001	针杆接头滑块	Connection slider	1	1	1	1	1
29	101511008	滑块导轨螺钉	Slider guide rail screw	2	2	2	2	2
30	101511005	螺钉 SM11/64×40×8	Screw SM11/64×40×8	1	1	1	1	1
31	13612001	松线钢绳固定架	Fixed frame	1	1	1	1	1
32	13612002	松线压板	Press plate	1	1	1	1	1
33	10112003	垫片	Washer	1	1	1	1	1

2. 上轴挑线分组件/Main shaft & thread take-up components

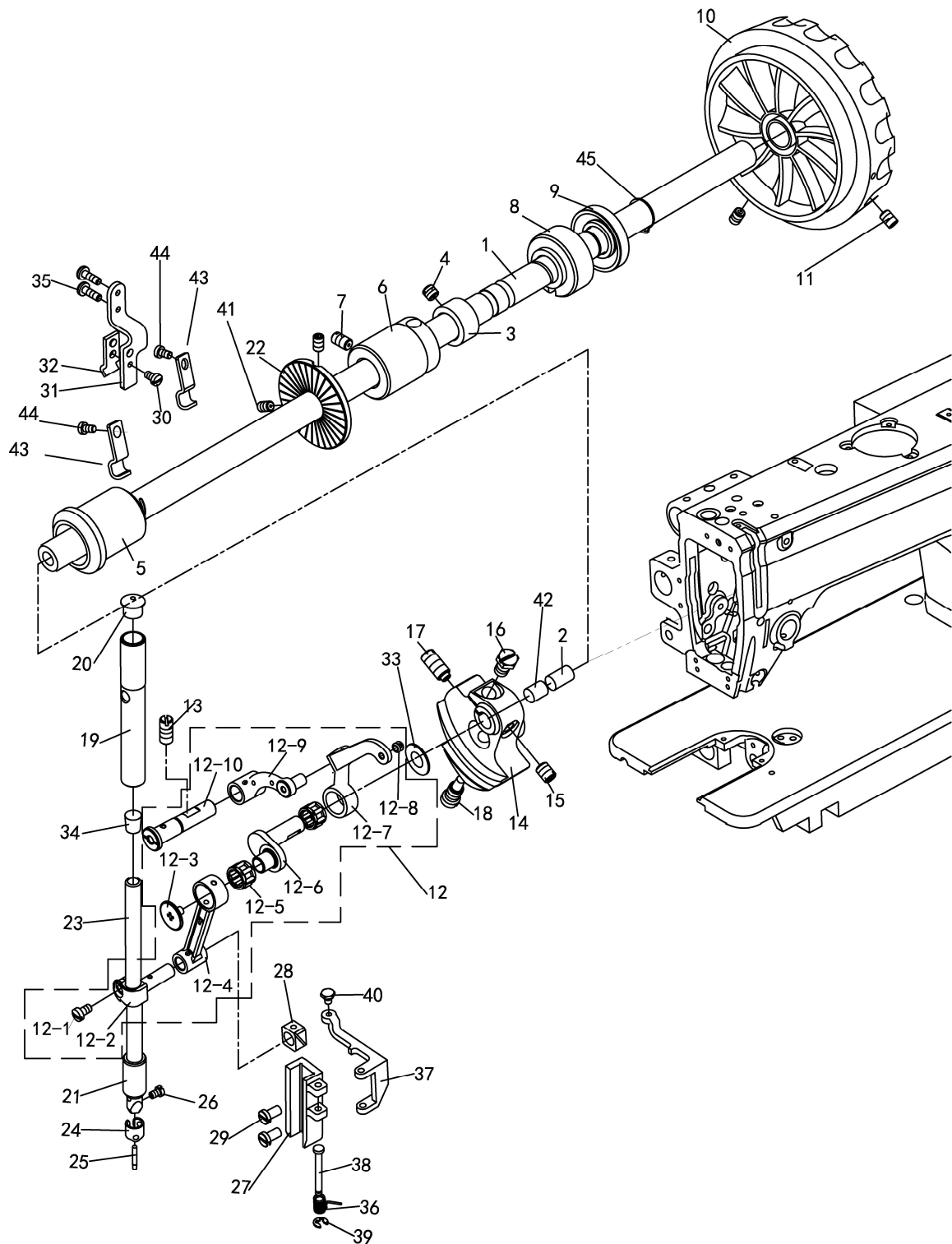

2.上轴挑线分组件/Main shaft & thread take-up components

序号 NO.	公司件号 Part NO.	名称 PartName	零件描述 Description	数量 Number				
				-3	XB	ZD	ST	H6+
34	13523001	毛毡	Oil felt for needle bar	2	2	2	2	2
35	101s11010	松线钢绳固定架螺	Fixed frame screw	2	2	2	2	2
36	13627002	铰链弹簧	Spring	1	1	1	1	1
37	13612003	松线铰链	Hinge	1	1	1	1	1
38	13626001	铰链销	Hinge pin	1	1	1	1	1
39	H05024	开口挡圈	Retaining ring	1	1	1	1	1
40	136512001	铰链螺钉	Hinge screw	1	1	1	1	1
41	S10035	螺钉 M5×8	Screw M5×8	2	2	2	2	2
42	10123002	针杆上毡塞	Oil felt for needle bar	1	1	1	1	1
43	114713006	电线固定夹	Clamps	2	2	2	2	2
44	135S15009	螺钉 SM15/64×28	Screw SM15/64×28	2	2	2	2	2
45	H03001	轴用弹性挡圈 15	Washer	1	1	1	1	1

3. 压料分组件/Presser components

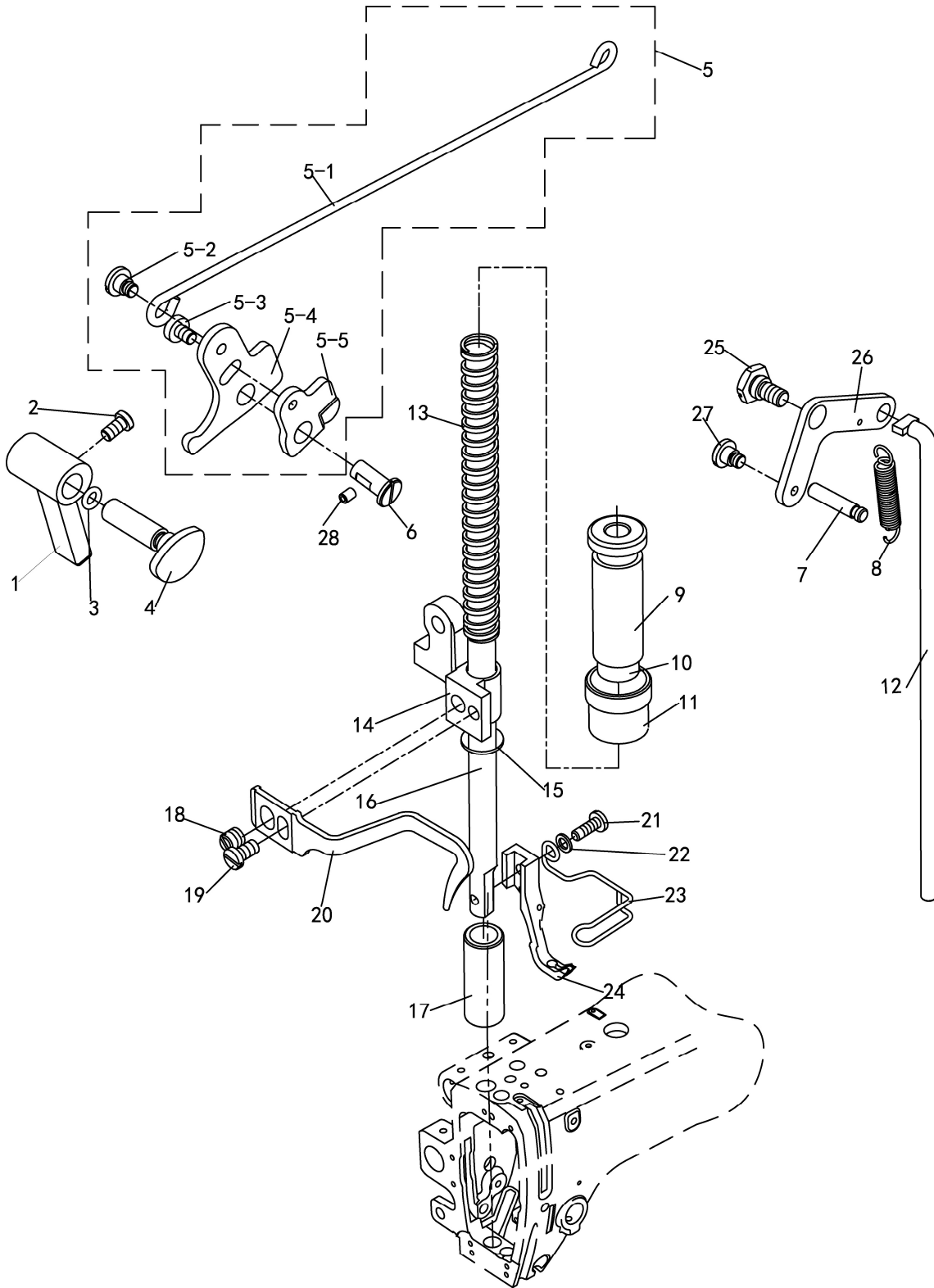

3.压料分组件/Presser components

序号 NO.	公司件号 Part NO.	名称 PartName	零件描述 Description	数量 Number				
				-3	XB	ZD	ST	H6+
1	14711005	压脚扳手	Presser foot wrench	1	1	1	1	1
2	101S11008	螺钉 SM11/64×40×8	Screw SM11/64×40×8	1	1	1	1	1
3	001009	O型圈 4.5X1.8	O-ring 4.5X1.8	1	1	1	1	1
4	13510004	压紧杆提升凸轮	Presser bar lifting cam	1	1	1	1	1
5	1351201200	膝控提升杠杆(左)组件	Knee lifter lever (left)assy	1	1	1	1	1
5-1	13512014	膝控提升拉杆	Knee lifter rod	1	1	1	1	1
5-2	135S11027	螺钉 SM3/16×28	screw SM3/16×28	1	1	1	1	1
5-3	135S11026	螺钉 SM11/64×40	Screw SM11/64×40	1	1	1	1	1
5-4	13512013	膝控提升杠杆(左)	Knee lifter lever (left)	1	1	1	1	1
5-5	13510005	松线凸轮	Tension releasing cam	1	1	1	1	1
6	114726007	松线凸轮销	Ensnion releasing cam melt	1	1	1	1	1
7	13526005	弹簧销	Pin for spring	1	1	1	1	1
8	13527010	膝腔提升杠杆(右)弹簧	Presser spring	1	1	1	1	1
9	1147NS30003	螺钉 M15×1	Screw M15×1	1	1	1	1	1
10	114709002	调压螺钉导套	Guide bushing	1	1	1	1	1
11	135S16003	螺母 M15×1	Nut M15×1	1	1	1	1	1
12	13512016	膝控提升杠杆	Knee lifter lever	1	1	1	1	1
13	13527011	压紧杆弹簧	Presser spring	1	1	1	1	1
14	114709001	压紧杆导架(加轴承)	Presser bar lifting bracket	1	1	1	1	1
15	30122022	压脚轴碟形密封圈	Gasket	1	1	1	1	1
16	13502019	压紧杆	Presser bar	1	1	1	1	1
17	13503013	压紧杆轴套	Presser bar bushing	1	1	1	1	1
18	101S15006	螺钉 SM15/64×28	Screw SM15/64×28	1	1	1	1	1
19	101S11008	螺钉 SM11/64×40×8	Screw SM11/64×40×8	1	1	1	1	1
20	114713002	大线勾	Thread guide	1	1	1	1	1
21	101S11009	螺钉 SM9/64×40×10.5	Screw SM9/64×40×10.5	1	1	1	1	1
22	13528007	小压脚螺钉垫片	Washer	1	1	1	1	1
23	13512017	防护勾	Defend hook	1	1	1	1	1
24	13516001	小压脚	Presser foot complete	1				1
	13516004	小压脚	Presser foot complete				1	
	114716006	小压脚	Presser foot complete		1			
	13516005	小压脚	Presser foot complete			1		
25	135S12002	螺钉 SM15/64×28	Screw SM15/64×28	1	1	1	1	1
26	13512015	膝控提升杠杆(右)	Knee lifter lever (right)	1	1	1	1	1
27	135S11027	螺钉 SM3/16×28	Screw SM3/16×28	1	1	1	1	1
28	113S14020	螺钉 SM11/64×40	Screw SM11/64×40	1	1	1	1	1

4.送料分组件/Feed mechanism components

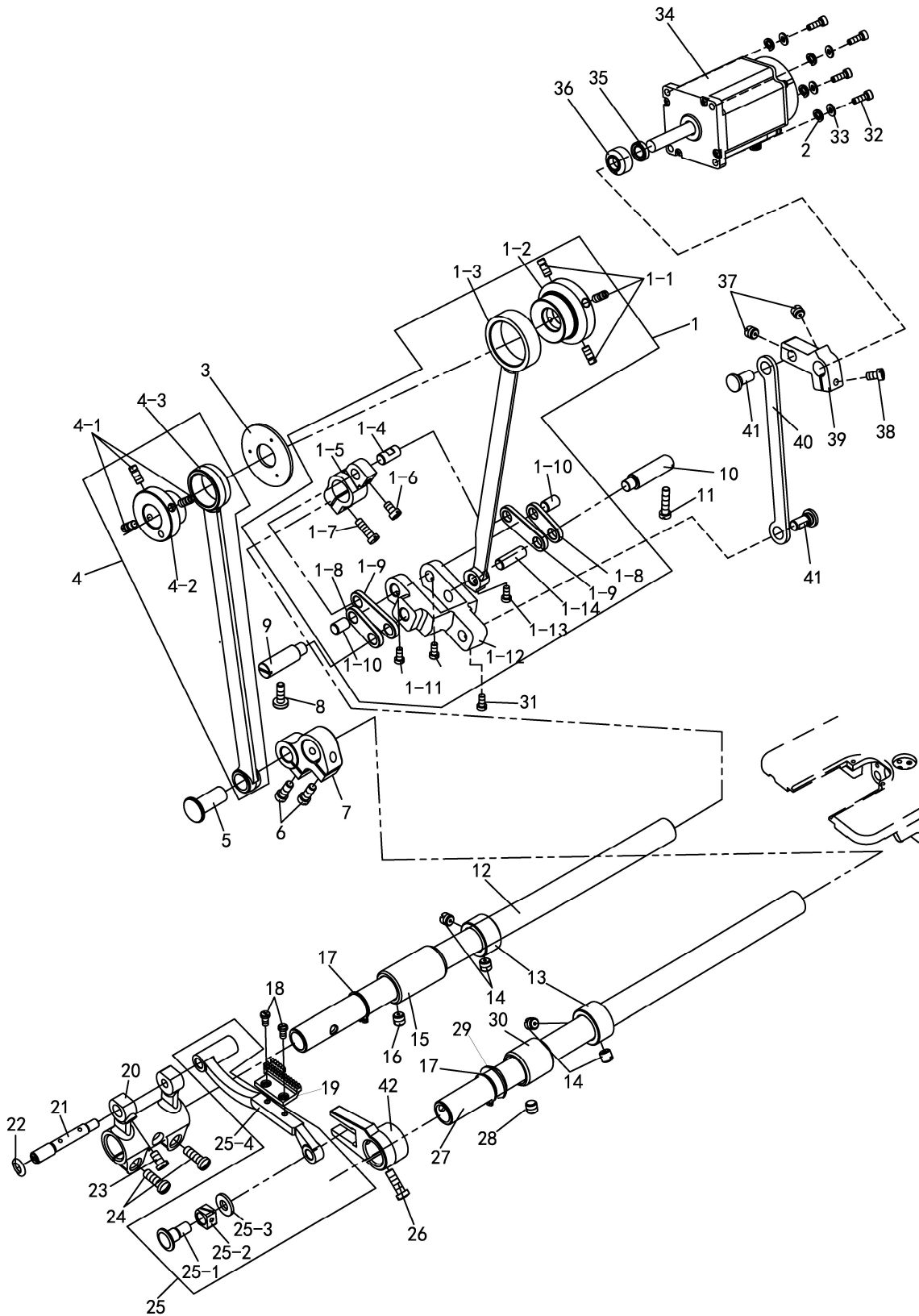

4.送料分组件/Feed mechanism components

序号 NO.	公司件号 Part NO.	名称 PartName	零件描述 Description	数量 Number				
				-3	XB	ZD	ST	H6+
1	11470501100	送布连杆组件	Rocker shaft connecting rod assy	1	1	1	1	1
1-1	135S15007	送布凸轮螺钉	Screw	3	3	3	3	3
1-2	13510003	送布凸轮	Feed drive eccentric cam	1	1	1	1	1
1-3	13505005	送布连杆	Rocker shaft connecting rod	1	1	1	1	1
1-4	13526001	送布曲柄短销	Walking foot crank short pin	1	1	1	1	1
1-5	13504018	送布曲柄 (右)	Feed rocker shaft crank assy	1	1	1	1	1
1-6	101S11025	螺钉 SM11/64×40×7	Screw SM11/64×40×7	1	1	1	1	1
1-7	409S11021	螺钉 SM11/64×40×14	Screw SM11/64×40×14	1	1	1	1	1
1-8	13505008	曲柄短连杆	connecting short link	1	1	1	1	1
1-9	13505007	曲柄长连杆	Crank long link	2	2	2	2	2
1-10	13526003	曲柄连杆短销	Crank connecting pin	2	2	2	2	2
1-11	201S11012	螺钉 SM9/64X40	Screw SM9/64X40	1	1	1	1	1
1-12	114704004	针距调节曲柄	Needle pitch adjusting link	1	1	1	1	1
1-13	209S14008	螺钉 SM11/64×40×4.5	Screw SM11/64×40×4.5	1	1	1	1	1
1-14	13502014	曲柄连杆长销	Crank connecting pin	1	1	1	1	1
2	10128003	平垫片	Washer	1	1	1	1	1
3	13528002	凸轮隔离片	Thrust collar	1	1	1	1	1
4	11350500200	抬牙连杆组件	Connecting rod assy	1	1	1	1	1
4-1	135S15007	螺钉 SM11/64×40	Screw SM11/64×40	1	1	1	1	1
4-2	13510001	抬牙凸轮	Feed drive eccentric cam	1	1	1	1	1
4-3	13505001	抬牙连杆	Connecting rod	1	1	1	1	1
5	13502009	抬牙曲柄铰链轴	Hinge pin	3	3	3	3	3
6	135S11048	螺钉 SM3/16×32	Screw SM3/16×32	1	1	1	1	1
7	13504019	抬牙右曲柄	Feed lifting rock shaft crank(right)	1	1	1	1	1
8	105S11019	螺钉 SM11/64×40 L=13	Screw SM11/64×40 L=13	1	1	1	1	1
9	13502016	针距调节曲柄定位销(左)	Adjusting link fulcrum shaft	2	2	2		2
10	13502017	针距调节曲柄定位销(右)	Adjusting link fulcrum shaft pin				2	
11	114S11004	螺钉 SM11/64×40×18	Screw SM 11/64×40×18	1	1	1		1
12	13602003	送布轴	Feed rocker shaft				1	
13	10108003	抬牙、送布轴紧圈	Thrust collar assy	2	2	2	2	2
14	101S15002	螺钉 SM1/4×40×6	Screw SM1/4×40×6	1	1	1	1	1
15	13603024	送布轴前轴套	Bushing for feed rock shaft(right)	1	1	1	1	1
16	135S15008	螺钉 SM15/64×28	Screw SM15/64×28	1	1	1	1	1
17	H03001	轴用弹性挡圈	Retaining ring	1	1	1	1	1
18	101S11018	螺钉 SM1/8×40 L=6	Screw SM1/8×40 L=6	2	2	2	2	2
19	13514001	送布牙	Feed dog	4	4	4	4	4
20	13504003	牙架曲柄	Feed crank assy	1	1	1	1	1
21	13502005	牙架曲柄偏心轴	Feed bar shaft	1	1	1	1	1
22	13528004	牙架垫圈	Washer	2	2	2	2	2
23	101S11008	螺钉 SM11/64×40×8	Screw SM11/64×40×8	2	2	2	2	2
24	101S11016	螺钉 SM3/16×28 L=14	Screw SM3/16×28 L=14	1		1		1
25	1350700300	牙架组件	Feed bar assy		1		1	
25-1	13502029	牙架连接销	Bracket connection pin					
25-2	13509007	滑块	Slider	1	1	1	1	1
25-3	13528009	垫片	Washer	1	1	1	1	1
25-4	13507001	牙架	Feed bar assy	1	1	1	1	1
26	409S11021	抬牙叉夹紧螺钉	Screw	1	1	1	1	1
27	13602004	抬牙轴	Feed lifting rock shaft	2	2	2	2	2

4.送料分组件/Feed mechanism components

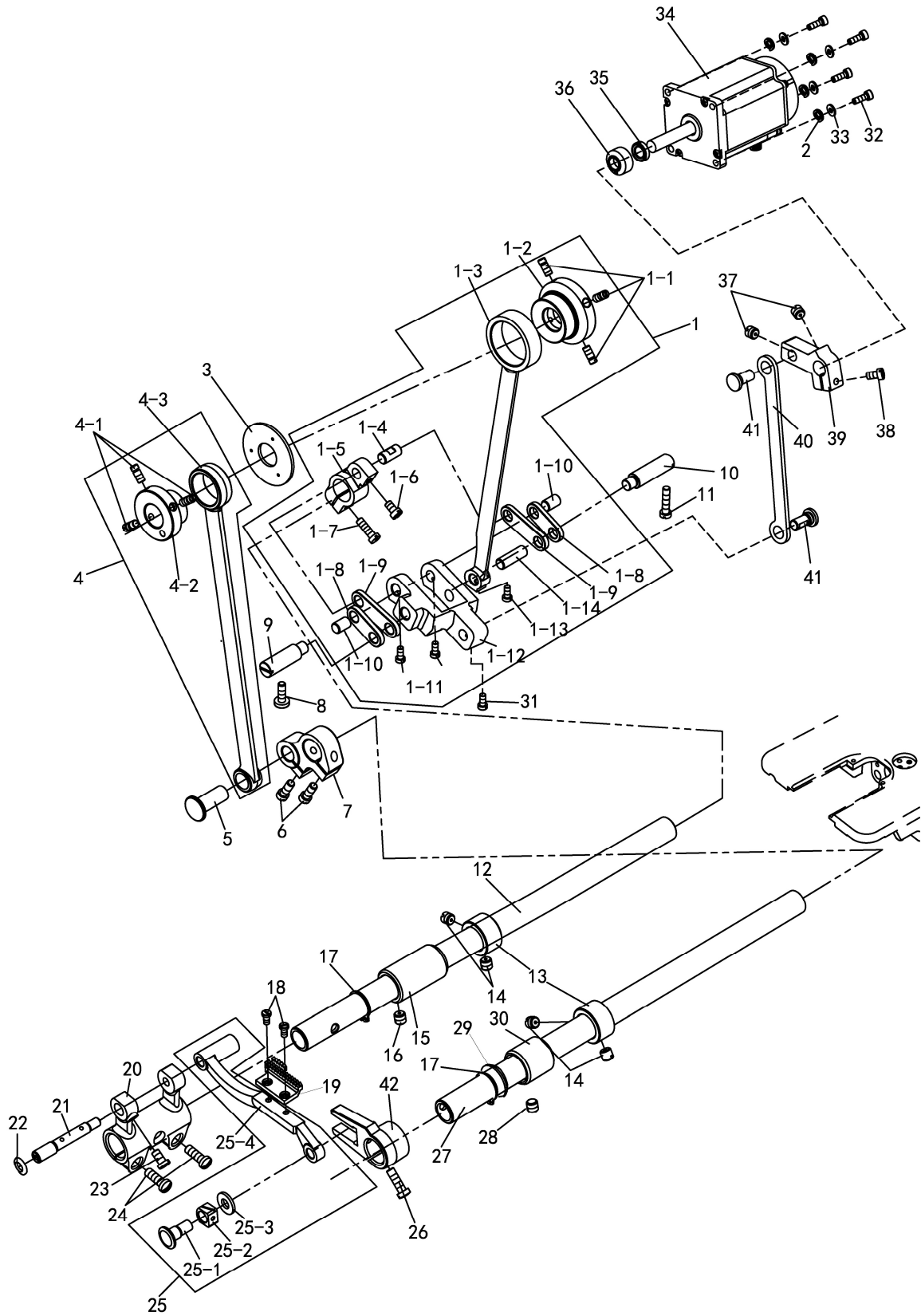

4.送料分组件/Feed mechanism components

序号 NO.	公司件号 Part NO.	名称 PartName	零件描述 Description	数量 Number				
				-3	XB	ZD	ST	H6+
28	135515009	拾牙轴前轴套螺钉	Screw SM15/64×28	1	1	1	1	1
29	13528006	垫圈	Washer	1	1	1	1	1
30	13603005	拾牙轴前轴套	Bushing for feed rock shaft(right)	1	1	1	1	1
31	201511012	S022 螺钉 SM9/64X40	Screw SM9/64X40	1	1	1	1	1
32	S05004	螺钉 M5×14	Screw M5×14	1	1	1	1	1
33	W03002	弹性垫圈	Sping washer	1	1	1	1	1
34	114733009	ZB-SMH6 调针距步进电机	Stepper motor	1	1	1	1	1
35	114922002	步进电机轴套油封	Stepper motor bushing oil seal	1	1	1	1	1
36	115003002	步进电机轴套	Stepper motor bushing	1	1	1	1	1
37	S10035	螺钉 M5×8	Screw M5×8	1	1	1	1	1
38	S05004	螺钉 M5×14	Screw M5×14	1	1	1	1	1
39	114704003	针距调节曲柄	Needle pitch adjust crnk	1	1	1	1	1
40	114705009	针距调节连杆	Stitch connecting rod	1	1	1	1	1
41	114926001	针距曲柄销	Needle pitch crank pin	1	1	1	1	1
42	13505004	拾牙叉	Feed forked connection	1	1	1	1	1

5.上送料部件/Upper feed Parts

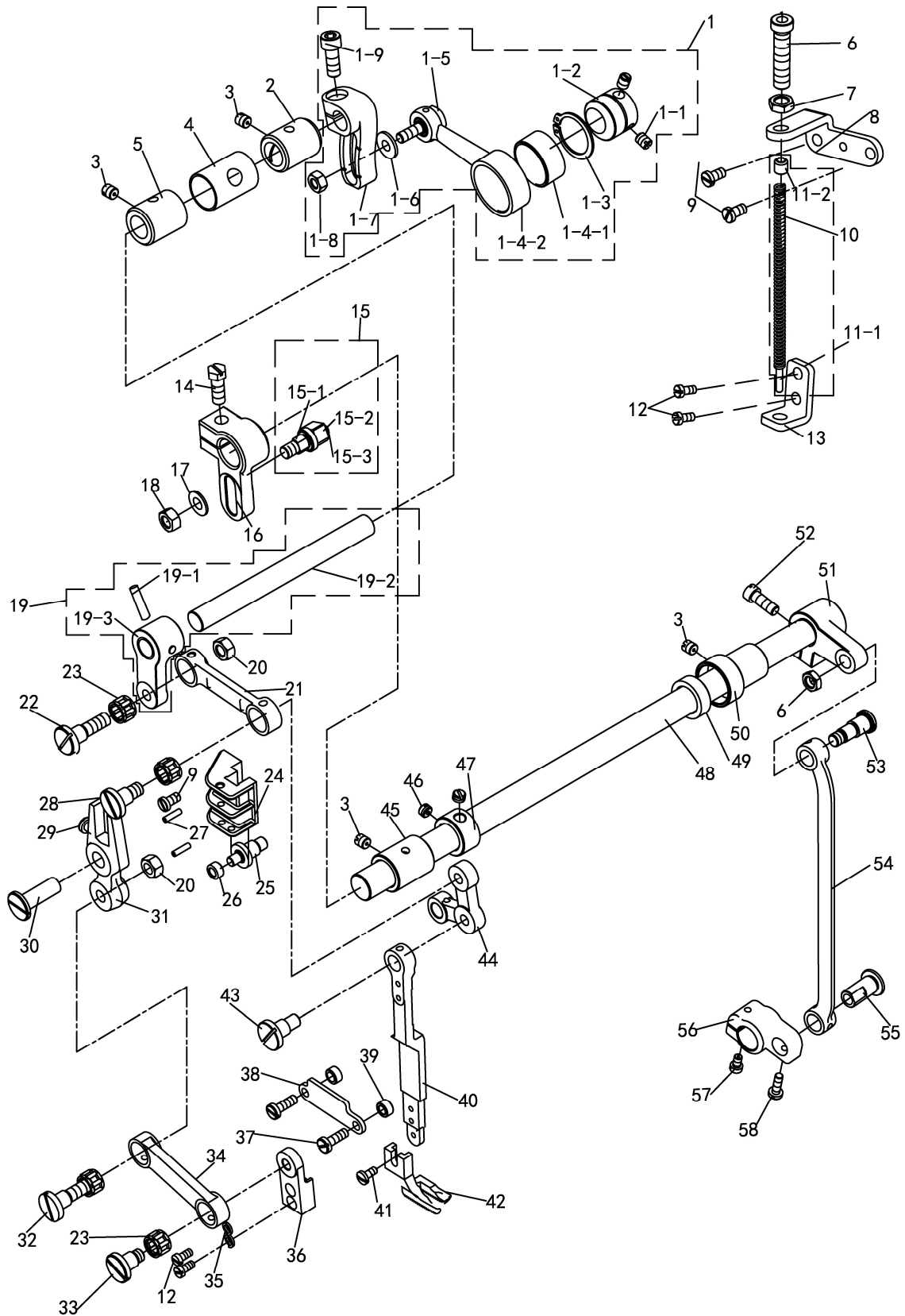

5.上送料部件/Upper feed Parts

序号 NO.	公司件号 Part NO.	名称 PartName	零件描述 Description	数量 Number				
				-3	XB	ZD	ST	H6+
1	11470500200	连杆组件	Connecting rod assy	1	1			1
	13505026000	连杆组件(4.5mm)	Connecting rod(4.5mm)			1		
	11470500500	连杆组件(2.5mm)	Connecting rod(2.5mm)				1	
1-1	101515007	螺钉 SM1/4×40×8	Screw SM1/4×40×8	2	2	2	2	2
1-2	114710001	压脚升降偏心轮	Eccentric wheel	1	1			1
	114710003	压脚升降偏心轮(4.5mm)	Eccentric wheel(4.5mm)			1		
	114710002	压脚升降偏心轮(2.5mm)	Eccentric wheel(2.5mm)				1	
1-3	H03061	轴用弹性挡圈 24	Retaining ring 24	1	1		1	1
		轴用弹性挡圈 26	Retaining ring 26			1		
1-4	11470500300	连杆小组件	Connecting rod widget	1	1		1	1
1-4-1	114703001	提升连杆衬套	Bushing	1	1		1	1
1-4-2	114705001	提升连杆	Lifting link	1	1		1	1
1-5	135520006	螺钉 M6×0.75	Screw M6×0.75	1	1	1	1	1
1-6	13528008	垫圈	Washer	1	1	1	1	1
1-7	13504013	偏心连杆调节曲柄	Presser lifting shaft	1	1	1	1	1
1-8	N02001	六角螺母 M6X0.75	Hex Nut M6X0.75	1	1	1	1	1
1-9	135511035	螺钉 SM1/4×24	Screw SM1/4×24	1	1	1	1	1
2	13603014	摆压脚提升轴后套	Presser lifting shaft back bushing	1	1	1	1	1
3	135515008	螺钉 SM15/64×28×6	Screw SM15/64×28×6	3	3	3	3	3
4	13603028	摆压脚提升中轴套	Presser lifting shaft bushing	1	1	1	1	1
5	13603013	摆压脚提升轴前套	Presser lifting shaft bushing	1	1	1	1	1
6	135530007	螺钉 SM9/32×28	Screw SM9/32×28	1	1	1	1	1
7	135516006	螺母 SM9/32×28	nut SM9/32×28	2	2	2	2	2
8	114712013	摆压脚调压螺钉架	Lifting presser bracket for spring	1	1	1	1	1
9	101511008	螺钉 SM11/64×40×8	Screw SM11/64×40×8	4	4	4	4	4
10	14727013	摆压脚调压杆弹簧	Lifting presser spring	1	1	1	1	1
11	1350202100	调压杆弹簧导柱	Presser spring guide	1	1	1	1	1
11-1	13502026	调压杆弹簧导柱杆	Presser spring guide rod	1	1	1	1	1
11-2	13502027	调压杆弹簧导柱套	Presser spring guide bushing	1	1	1	1	1
12	201511012	螺钉 SM9/64X40	Screw SM9/64X40	4	4	4	4	4
13	114712012	提升压脚导柱架	Lifting presser guide plate assy	1	1	1	1	1
14	402513011	螺钉 SM15/64×28×18	Screw SM15/64×28×18	1	1	1	1	1
15	1420900400	摆动轴左曲柄调节柱组件	Crank shaft complete asm	1	1	1	1	1
15-1	142530011	摆动轴左曲柄调节柱	Crank shaft complete	1	1	1	1	1
15-2	14209004	曲柄调节柱滑块	Slide block	1	1	1	1	1
15-3	H05029	开口挡圈	Split ring	1	1	1	1	1
16	13504020	压脚摆动前曲柄	Presser swing shaft	1	1	1	1	1
17	11628005	拾牙叉固定螺钉垫圈	Washer	1	1	1	1	1
18	135516005	螺母 SM1/4×24	Nut SM1/4×24	1	1	1	1	1
19	1350401500	压脚升降前曲柄组件	Presser lifting crank	1	1	1	1	1
19-1	113602001	压脚升降轴	Presser lifting crank	1	1	1	1	1
19-2	13526007	圆锥销	Taper pin	1	1	1	1	1
19-3	13504009	压脚升降前曲柄	Pressure foot lifting shaft	1	1	1	1	1
20	135516004	螺母 SM1/4×40	Nut SM1/4×40	2	2	2	2	2
21	13505027	压脚送料曲柄连杆(加轴承)	Presser feed crank link	1	1	1	1	1
22	135520012	螺钉 SM1/4×40	Screw SM1/4×40	1	1	1	1	1
23	10124001	滚针轴承	Needle bearing	4	4	4	4	4
24	13509004	提升压脚导位板	Lifting presser plate	1	1	1	1	1

5. 上送料部件/Upper feed Parts

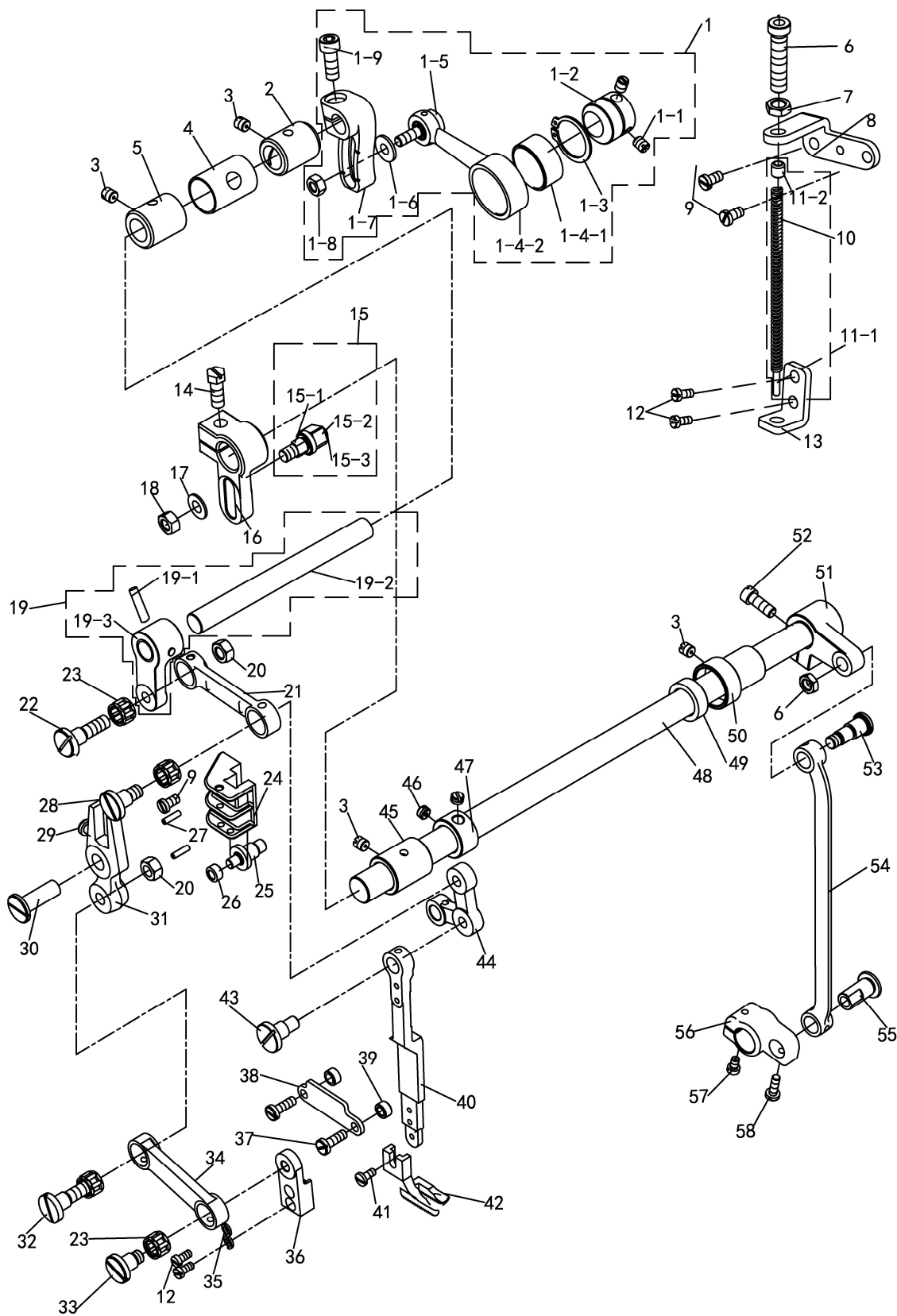

5.上送料部件/Upper feed Parts								
序号 NO.	公司件号 Part NO.	名称 PartName	零件描述 Description	数量 Number				
				-3	XB	ZD	ST	H6
25	1147NS30002	送料曲柄导柱轴	Guide shaft	1	1	1	1	1
26	13508004	提升压脚导柱轴滚柱	Needle of bearing	1	1	1	1	1
27	P03035	弹性圆柱销 3X8	Spring round pin 3X8	2	2	2	2	2
28	1147NS20001	螺钉 SM1/4×40×7	Screw SM1/4×40×7	1	1	1	1	1
29	101511001	螺钉 SM3/16X28 L=9	Screw SM3/16X28 L=9	1	1	1	1	1
30	13526006	摆压脚叉形杆销	Pin	1	1	1	1	1
31	13505030	摆压脚叉形杆(加轴承)	Fork lever	1	1	1	1	1
32	135520013	螺钉 SM1/4×40	Screw SM1/4×40	1	1	1	1	1
33	135520014	螺钉 SM1/4×40	Screw SM1/4×40	1	1	1	1	1
34	13505028	摆压脚连杆 (加轴承)	Link of walking foot	1	1	1	1	1
35	W02002	垫圈 4	Washer	2	2	2	2	2
36	13601015	摆压脚杆座	Holder for walking foot bar	1	1	1	1	1
37	116511005	螺钉 SM11/64×40×13	Screw SM11/64×40×13	2	2	2	2	2
38	114712020	提升压脚连接压板	Lifting presser sway crank guide pin	1	1	1	1	1
39	114708001	压脚连杆压板垫块	Shim	2	2	2	2	2
40	13501006	摆压脚杆	Presser rod guide	1	1	1	1	1
41	135511030	螺钉 SM9/64×40	Screw SM9/64×40	1	1	1	1	1
42	13516002	摆压脚	Walking foot	1				1
	13516003	摆压脚	Walking foot				1	
	114716007	摆压脚	Walking foot		1			
	13516006	摆压脚	Walking foot			1		
43	1147NS20002	螺钉 SM1/4×40	Screw SM1/4×40	1	1	1	1	1
44	114704001	压脚送料曲柄(加轴承)	Presser feed crank	1	1	1	1	1
45	13508008	压脚摆动轴前轴套	Presser swing shaft front bushing (left)	1	1	1	1	1
46	135515004	螺钉 SM1/4×40×4	Screw SM1/4×40×4	2	2	2	2	2
47	13508009	紧圈	Shaft washer	1	1	1	1	1
48	13502023	压脚摆动轴	Presser swing shaft	1	1	1	1	1
49	11472200200	摆动轴后套油封	Oil seal	1	1	1	1	1
50	13503014	压脚摆动轴中轴套	Presser swing middle shaft bushing (right)	1	1	1	1	1
51	13504023	压脚摆动后曲柄	Presser swing crank(right)	1	1	1	1	1
52	402513011	螺钉 SM15/64×28×18	Screw SM15/64×28×18	1	1	1	1	1
53	135520005	螺钉 SM9/32×28	Screw SM9/32×28	1	1	1	1	1
54	13505014	摆压脚大连杆	Presser swing crank(right)rod	1	1	1	1	1
55	135520004	大连杆曲柄连接销	Pin	1	1	1	1	1
56	13504022	送布轴曲柄 (中)	Feed rocker shaft crank middle	1	1	1	1	1
57	101511025	螺钉 SM11/64×40×7	Screw SM11/64×40×7	1	1	1	1	1
58	116511005	螺钉 SM11/64×40×13	Screw SM11/64×40×13	1	1	1	1	1

6. 旋梭部件/Hook components

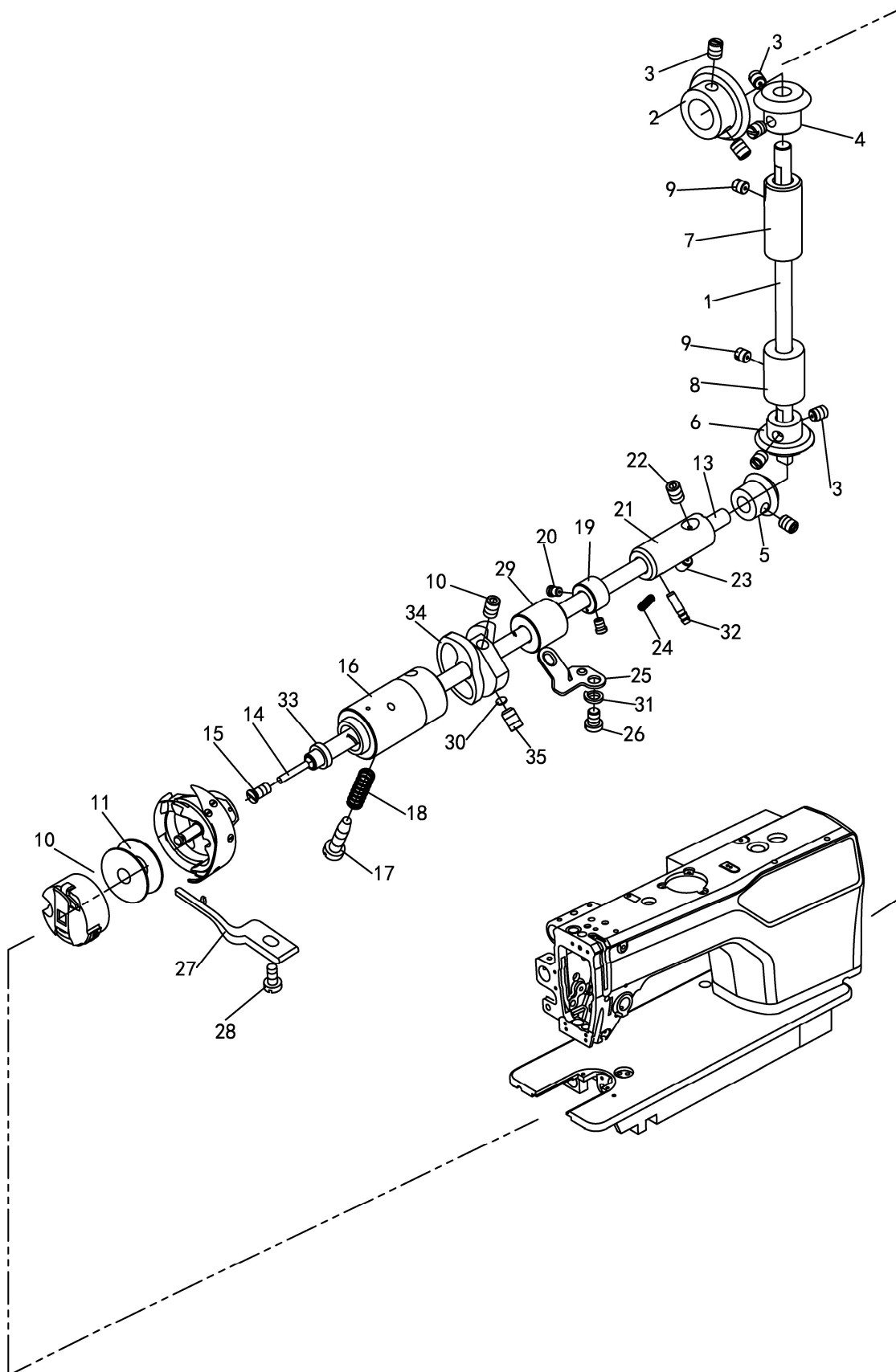

6.旋梭部件/Hook components

序号 NO.	公司件号 Part NO.	名称 PartName	零件描述 Description	数量 Number				
				-3	XB	ZD	ST	H6+
1	13502002	竖轴	Upright shaft	1	1	1	1	1
2	13525001	上轴伞齿轮	Gear asm	1	1	1	1	1
3	101s15007	螺钉 SM1/4x40x8	Screw SM1/4x40x8	8	8	8	8	8
4	13525002	竖轴伞齿轮 (上)	Gear asm	1	1	1	1	1
5	13525003	下轴伞齿轮	Pinion asm	1	1	1	1	1
6	13525004	竖轴伞齿轮 (下)	Gear asm	1	1	1	1	1
7	13503018	竖轴轴套 (上)	Bushing upper	1	1	1	1	1
8	13503019	竖轴轴套(下)	Upring shaft bushing lower	1	1	1	1	1
9	135515008	螺钉 SM15/64x28	Screw SM15/64x28	2	2	2	2	2
10	13618001	梭心套组件	Hook asm	1	1	1	1	1
11	10818501	梭芯	Bobbin	1	1	1	1	1
12	13618003	旋梭(无尾)	Hook asm (without tail)			1		
	13618007	旋梭(有尾)	Hook asm (with tail)	1	1		1	1
13	13602006	下轴	Hook driving shaft	1	1	1	1	1
14	10123003	下轴滤油塞	Oil wick	1	1	1	1	1
15	135520007	螺钉 SM3/16x32	Screw SM3/16x32	1	1	1	1	1
16	13503009	下轴前轴套	Bushing front	1	1	1	1	1
17	135520008	螺钉 SM15/64x28	Screw SM15/64x28	1	1	1	1	1
18	13527005	油量调节弹簧	Spring	1	1	1	1	1
19	10108002	下轴紧圈	Thrust shrink collar asm	1	1	1	1	1
20	101S11012	螺钉 SM11/64x40x4.8	Screw SM11/64x40x4.8	2	2	2	2	2
21	13603025	下轴后轴套	Bushing rear	1	1	1	1	1
22	135515009	螺钉 SM15/64x28	Screw SM15/64x28	1	1	1	1	1
23	13502008	柱塞	Plunger	1	1	1	1	1
24	13527006	柱塞弹簧	Plunger spring	1	1	1	1	1
25	13512009	档板	Guide plate	1	1	1	1	1
26	135511019	螺钉 SM15/64x28	Screw SM15/64x28	1	1	1	1	1
27	13512010	旋梭定位勾	Rotating hook positioner	1	1	1	1	1
28	101S11011	螺钉 SM11/64x40x9.5	Screw SM11/64x40x9.5	1	1	1	1	1
29	13603026	下轴中轴套	Bushing middle	1	1	1	1	1
30	13628003	切线凸轮螺钉垫片	Washer	2	2	2	2	2
31	W02004	档板螺钉弹簧垫圈	Washer	1	1	1	1	1
32	13521001	下轴轴套油管	Oil pipe for hook shaft bushing	1	1	1	1	1
33	11522001	下轴油封	Plunger	1	1	1	1	1
34	13610003	切线凸轮	Thread trimmer cam	1	1	1	1	1
35	116S14005	螺钉 SM1/4x40x10	Screw SM1/4x40x10	2	2	2	2	2

7. 润滑组件/Oil lubrication components

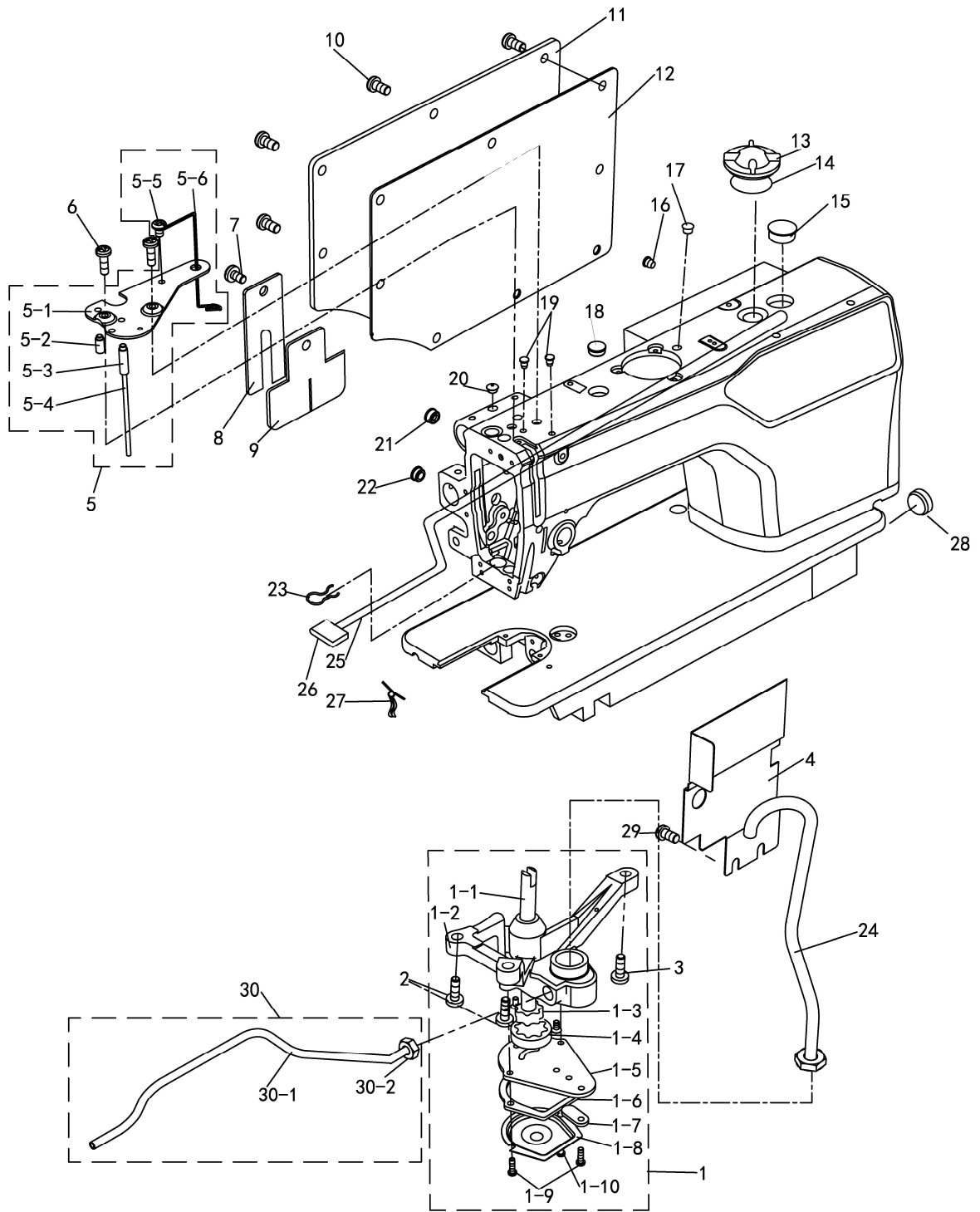

7.润滑组件/Oil lubrication components

序号 NO.	公司件号 Part NO.	名称 PartName	零件描述 Description	数量 Number				
				-3	XB	ZD	ST	H6
1	1352000200	油泵组件	Oil pump asm	1	1	1	1	1
1-1	13502024	油泵体短轴	Shaft for oil pump	1	1	1	1	1
1-2	13520001	油泵体	Oil pump	1	1	1	1	1
1-3	13525006	油泵小齿轮	Small gear for oil pump	1	1	1	1	1
1-4	13525005	油泵大齿轮	Big gear for oil pump	1	1	1	1	1
1-5	13512021	油泵体盖板	Cover for oil pump	1	1	1	1	1
1-6	13512024	油泵滤网	Oil pump Filter	1	1	1	1	1
1-7	13512022	油泵调节板	Adjusting plate for oil pump	1	1	1	1	1
1-8	13512023	油泵滤网盖板	Oil pump Filter cover	1	1	1	1	1
1-9	S02032	油泵体盖板螺钉 M3×6	Screw M3×6	2	2	2	2	2
1-10	135511037	螺钉 M3×10	Screw M3×10	3	3	3	3	3
2	105S11019	螺钉 SM11/64×40×13	Screw SM11/64×40×13	2	2	2	2	2
3	105S11019	螺钉 SM11/64×40×13	Screw SM11/64×40×13	1	1	1	1	1
4	31612023	挡油板	Keep off plate	1	1	1	1	1
5	1351202400	油线固定板大组件	Oil wick set plate complete	1	1	1	1	1
5-1	13512031	油线固定板	Oil line fixing plate	1	1	1	1	1
5-2	13521006	油线固定板油管(短)	Oil line fixing plate oil pipe(short)	1	1	1	1	1
5-3	13521005	油线固定板油管(长)	Oil line fixing plate oil pipe(long)	1	1	1	1	1
5-4	13523007	油线固定板油线	Oil line fixing plate oil line	1	1	1	1	1
5-5	101S01010	复合槽螺钉 SM9/64×40	Screw SM9/64×40	1	1	1	1	1
5-6	13534001	油线固定勾	Oil line fixing hook	1	1	1	1	1
6	101S11010	螺钉 SM9/64×40×11	Screw SM9/64×40×11	2	2	2	2	2
7	101S11004	螺钉 SM3/16X28 X7	Screw SM3/16X28 X7	1	1	1	1	1
8	305102	小挡油板	Keep off plate	1	1	1	1	1
9	14722011	小挡油板羊毛毡	Keep off plate wool felt	1	1	1	1	1
10	101S11001	螺钉 SM3/16X28×9	Screw SM3/16X28×9	8	8	8	8	8
11	304715	后盖板	Side plate	1	1	1	1	1
12	14722006	后盖板密封垫片	Gasket	1	1	1	1	1
13	10111004	油窗	Oil sight window	1	1	1	1	1
14	10122019	油窗 O 型圈	O-ring	1	1	1	1	1
15	13522008	橡皮塞 (φ25.5)	Rubber plug(φ25.5)	1	1	1	1	1
16	13522003	橡皮塞 (φ8.8)	Rubber plug(φ8.8)	1	1	1	1	1
17	10122005	挑线连杆销螺孔塞	Take-up link pin screw plug	1	1	1	1	1
18	13522001	面板橡皮塞 (φ19)	Rubber plug(φ19)	1	1	1	1	1
19	13522005	橡皮塞 (φ5.7)	Rubber plug(φ5.7)	2	2	2	2	2
20	14022013	A4S-0754 孔塞 (φ8.5)	Rubber plug(φ8.5)	1	1	1	1	1
21	12922001	橡皮塞 (φ12.5)	Rubber plug(φ12.5)	1	1	1	1	1
22	13522002	面板橡皮塞 (φ11.8)	Rubber plug(φ11.8)	1	1	1	1	1
23	114727007	回油毡压簧	Felt compression spring	1	1	1	1	1
24	1352100700	上轴油管组件	Upper shaft tubing assembly	1	1	1	1	1
25	12921002	回油管 φ3Xφ4	Oil return pipeφ3Xφ4	1	1	1	1	1
26	13523003	回油管滤油毡	Oil felt	1	1	1	1	1
27	10423005	油线 2.5x260/2.5x290	Oil wick	1	1	1	1	1
28	13522004	橡皮塞 (φ27)	Rubber plug(φ27)	1	1	1	1	1
29	112511014	螺钉 SM11/64×40×5.3	Screw SM11/64×40×5.3	2	2	2	2	2
30	1362100100	下轴油管组件	Oil pipe for arm lower shaft	1	1	1	1	1
30-1	13621001	下轴油管	Oil pipe for lower shaft	1	1	1	1	1
30-2	13636001	下轴油管接头	Lower shaft Hose connector	1	1	1	1	1

8.切线装置部件/Thread trimmer components

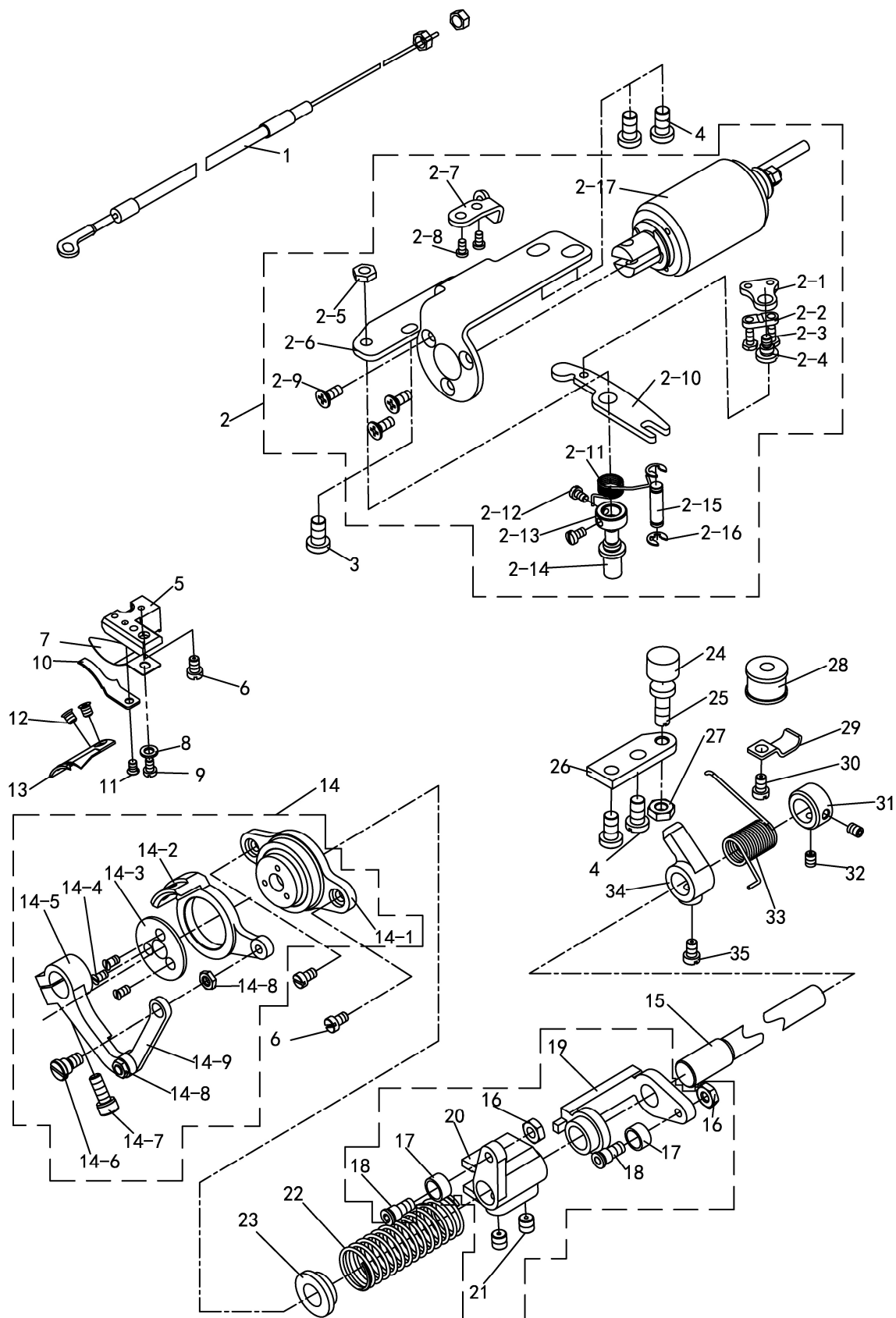

8.切线装置部件/Thread trimmer components

序号 NO.	公司件号 Part NO.	名称 PartName	零件描述 Description	数量 Number				
				-3	XB	ZD	ST	H6+
1	1361300300	松线钢丝绳组件	Loose wire rope assembly	1	1	1	1	1
2	1363000600	剪线电磁铁大组件	Thread electromagnet drive assembly	1	1	1	1	1
2-1	13612007	软线支撑板	Adapter	1	1	1	1	1
2-2	13612008	软线连板	Adapter	1	1	1	1	1
2-3	305512005	螺钉 SM1/8x44	Screw	2	2	2	2	2
2-4	136520001	螺钉 SM11/64x40	Screw SM11/64x40	1	1	1	1	1
2-5	114516005	螺母 SM15/64x28	Nut SM15/64x28	1	1	1	1	1
2-6	13612012	剪线电磁铁安装架	Wire trimming electromagnet mounting bracket	1	1	1	1	1
2-7	13612009	软线座	The mounting plate	1	1	1	1	1
2-8	101511025	螺钉 SM11/64x40x7	Screw SM11/64x40x7	2	2	2	2	2
2-9	407517001	螺钉 M4x10	Screw M4x10	3	3	3	3	3
2-10	13612006	驱动板	Thread trimmer driving lever	1	1	1	1	1
2-11	13627004	驱动板弹簧	Spring	1	1	1	1	1
2-12	101511005	螺钉 SM9/64x40x6	Screw SM9/64x40x6	2	2	2	2	2
2-13	30108004	驱动板轴紧圈	Shrink collar	1	1	1	1	1
2-14	13602007	驱动板轴	Shaft	1	1	1	1	1
2-15	13626005	剪线电磁铁销	Pin	1	1	1	1	1
2-16	H05012	挡圈	Ring	2	2	2	2	2
2-17	1363000100	剪线电磁铁传动组件	Wire cutting electromagnet drive assembly	1	1	1	1	1
3	101511011	螺钉 SM11/64x40x	Screw SM11/64x40x9.5	1	1	1	1	1
4	201511029	螺钉 SM15/64X28x11	Screw SM15/64X28x11	4	4	4	4	4
5	13601007	定刀座	Bracket for fixed blade	1	1	1	1	1
6	101511025	螺钉 SM11/64x40x7	Screw SM11/64x40x7	3	3	3	3	3
7	13612010	栏线板	Thread guide	1	1	1	1	1
8	13628011	栏线板垫片	Gasket	1	1	1	1	1
9	101511005	螺钉 SM9/64x40x6	Screw SM9/64x40x6	1	1	1	1	1
10	13619001	定刀片	Fixed blade	1	1	1	1	1
11	136517001	螺钉 SM9/64x40x4	Screw SM9/64x40x4	1	1	1	1	1
12	113517002	螺钉 SM11/64x40x	Screw SM11/64x40x4.5	2	2	2	2	2
13	13619002	动刀片	Movable knife (left)	1	1	1	1	1
14	1360100800	刀架组件	Knife holding bracket saddle asm	1	1	1	1	1
14-1	42209006	刀架	Knife holding bracket saddle	1	1	1	1	1
14-2	42204008	切线刀架 L	Knife base (left)	1	1	1	1	1
14-3	42212049	刀架垫圈	Washer	1	1	1	1	1
14-4	422517006	螺钉 SM1/8x44x5.4	Screw SM1/8x44x5.4	3	3	3	3	3
14-5	13604001	剪线电磁铁驱动曲柄	Knife driving crank	1	1	1	1	1
14-6	422520006	螺钉 SM11/64x40x	Screw SM11/64x40x5.5	2	2	2	2	2
14-7	S05005	螺钉 M5x12	Screw M5x12	1	1	1	1	1
14-8	422516002	螺母 SM11/64x40	Nut SM11/64x40	2	2	2	2	2
14-9	42205008	刀架连杆	Link	1	1	1	1	1
15	13602008	凸轮曲柄轴	Knife driving shaft	1	1	1	1	1
16	136517005	滚轮螺母 SM3/16x28	Nut SM3/16x28	2	2	2	2	2
17	13609002	滚轮	Cam follower	2	2	2	2	2
18	136520003	螺钉 SM3/16x28x8	Screw SM3/16x28x8	2	2	2	2	2
19	11360400300	左右曲柄组件	Left and right crank assembly	1	1	1	1	1
21	136514002	螺钉 SM15/64X28x6	Screw SM15/64X28x6	2	2	2	2	2

8.切线装置部件/Thread trimmer components

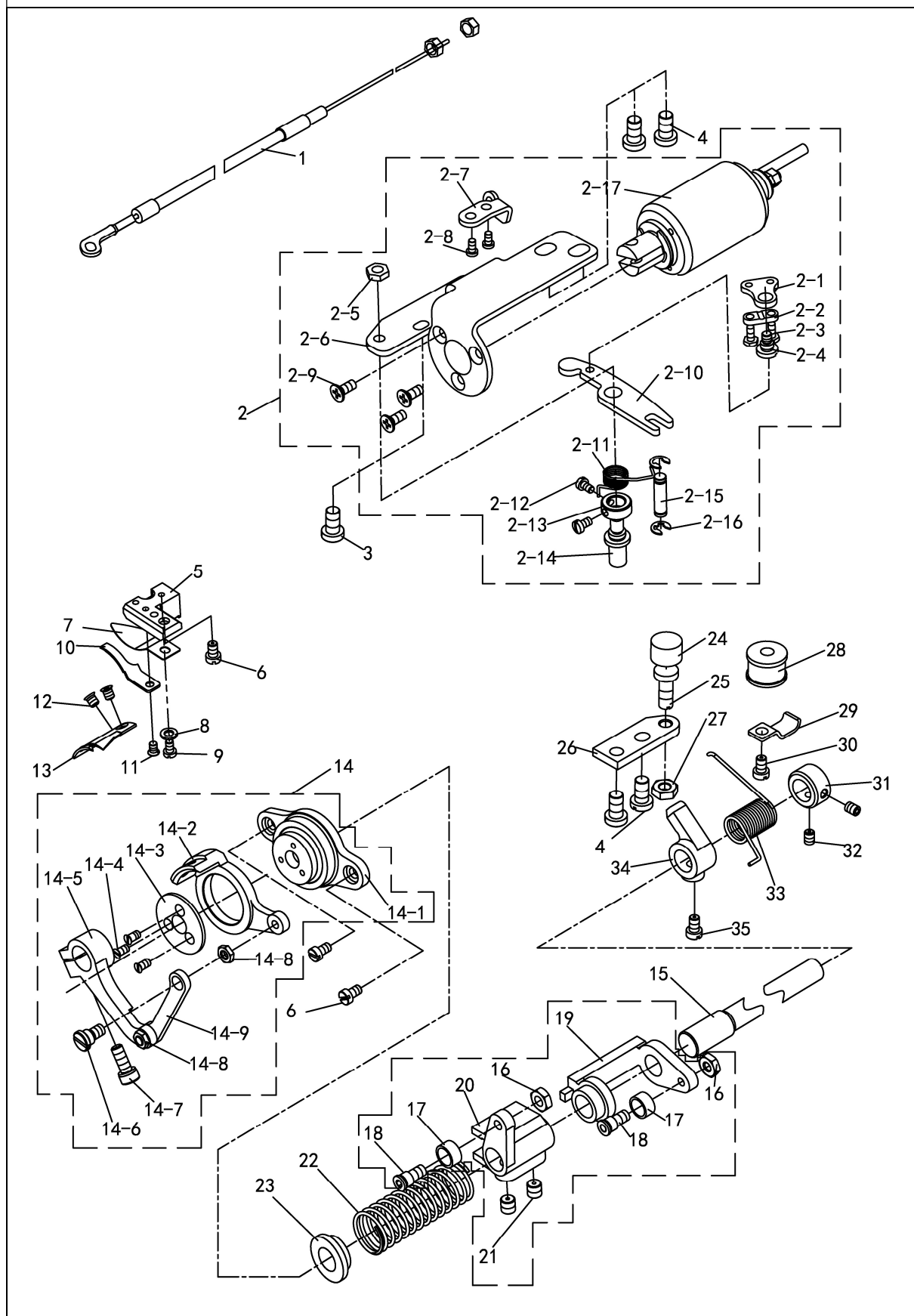

8.切线装置部件/Thread trimmer components

序号 NO.	公司件号 Part NO.	名称 PartName	零件描述 Description	数量 Number				
				-3	XB	ZD	ST	H6+
22	13627005	曲柄轴弹簧	Spring	1	1	1	1	1
23	13601010	扭簧端盖	Torsion spring end cap	1	1	1	1	1
24	114728003	缓冲垫	Cushion	1	1	1	1	1
25	136530002	止动螺钉 M6×16	Screw M6×16	1	1	1	1	1
26	13612011	止动板	Stopper plate	1	1	1	1	1
27	205516002	螺母 M6×3.5	Nut M6×3.5	1	1	1	1	1
28	114722006	电线单孔塞	Wire plug	1	1	1	1	1
29	12312011	电线固定夹	Cable clip	1	1	1	1	1
30	101511025	螺钉 SM11/64×40×7	Screw SM11/64×40×7	1	1	1	1	1
31	20108001	凸轮轴紧圈	Thrusr tighten collar asm	1	1	1	1	1
32	113514020	螺钉 SM11/64×40×6	Screw SM11/64×40×6	2	2	2	2	2
33	13627006	凸轮轴扭簧	Spring	1	1	1	1	1
34	13601011	限位块	Stopper	1	1	1	1	1
35	S10018	螺钉 M6×0.75×6	Screw M6×0.75×6	1	1	1	1	1

9.自动倒送料开关组件/Automatic reverse feed components

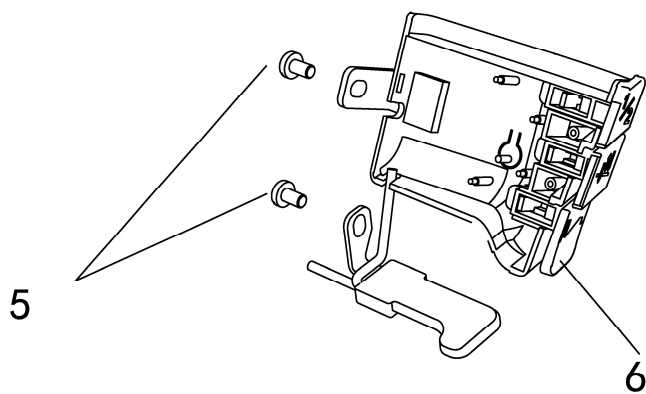
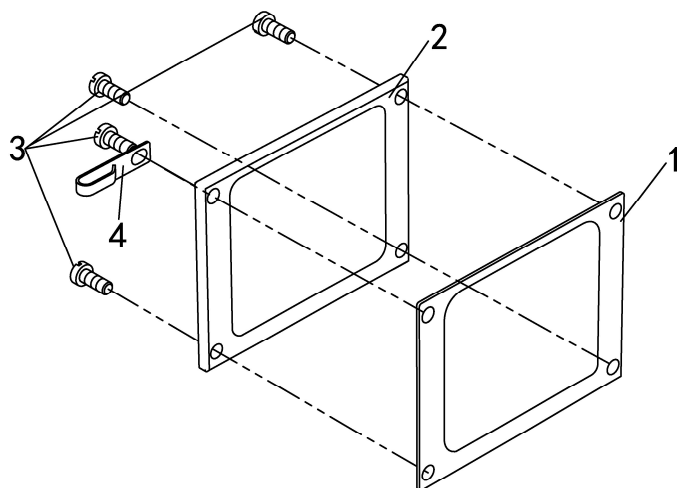

9.自动倒送料开关组件/Automatic reverse feed components

序号 NO.	公司件号 Part NO.	名称 PartName	零件描述 Description	数量 Number				
				-3	XB	ZD	ST	H6+
1	13628009	倒缝电磁铁罩垫片	Seals washer	1	1	1	1	1
2	302662	倒缝电磁铁罩	Backstitch solenoid cover	1	1	1	1	1
3	101S11001	螺钉 SM3/16×28×9	Screw SM3/16×28×9	4	4	4	4	4
4	41312003	油管固定架	Oil tube hohder	1	1	1	1	1
5	101S11004	螺钉 SM3/16X28 X7	Screw SM3/16X28 X7	2	2	2	2	2
6	11473000500	倒缝电磁铁开关组件	Switch assembly	1	1	1	1	1

10.机头附件/Machine head accessories

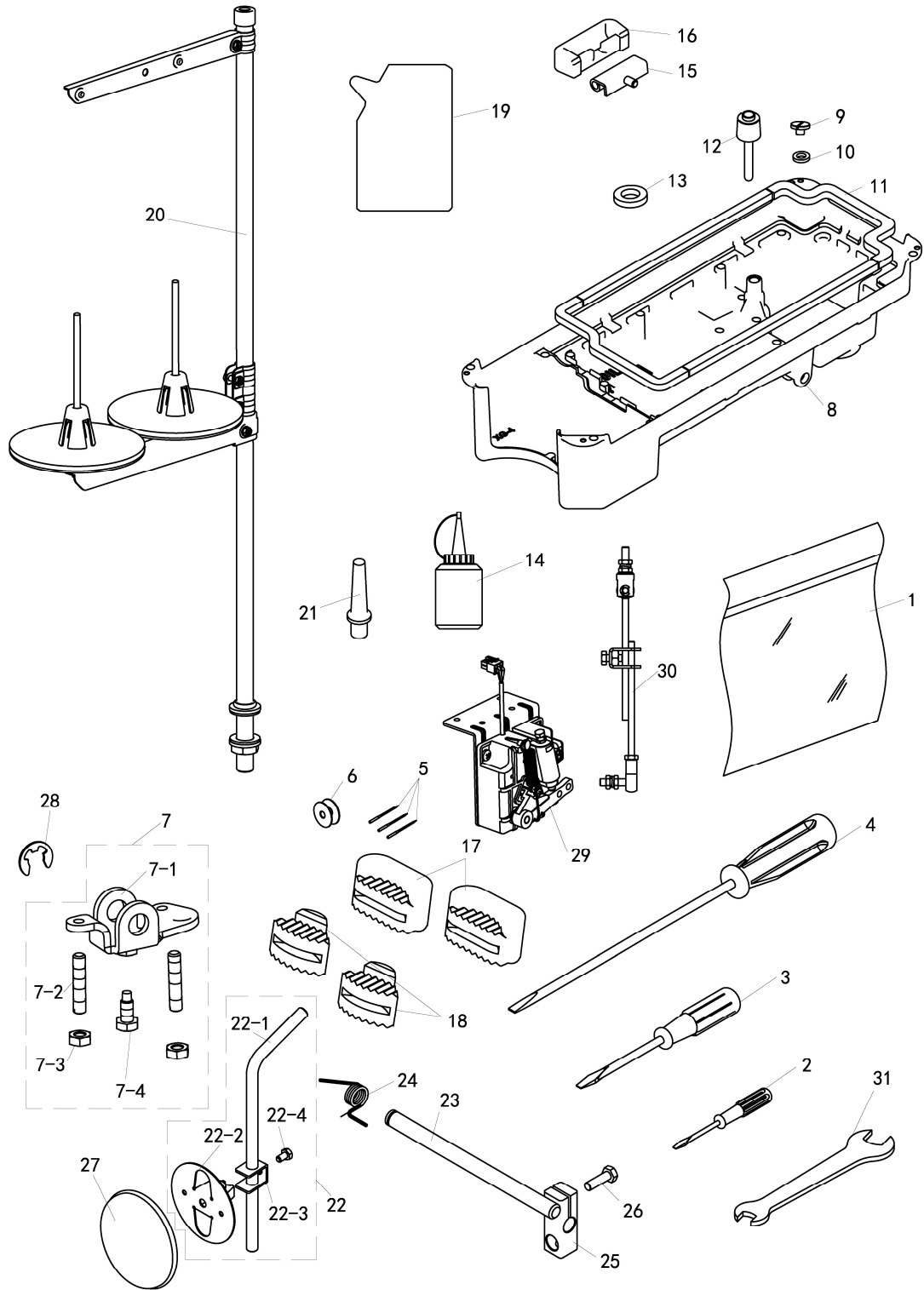

10.机头附件/Machine head accessories

序号 NO.	公司件号 Part NO.	名称 PartName	零件描述 Description	数量 Number				
				-3	XB	ZD	ST	H6+
1	115031022	A5-1311 防尘罩	Machine head cover	1	1	1	1	1
2	10131004	螺钉起子 (小)	Screw driver(small)	1	1	1	1	1
3	10131003	螺钉起子 (中)	Screw driver(middle)	1	1	1	1	1
4	20731047	螺丝刀	Screw driver(large)	1	1	1	1	1
5	13517002	机针 DP×17 23#(国产)	Needle(DP×17 23#)	10		10		10
	114717006	机针(DP×17 21#)(国产)	Needle(DP×17 21#)		10			
	11617002	机针(DP×5 14#)	Needle(DP×5 14#)				4	
6	10818501	梭芯	Bobbin	5	5	5	5	5
7	1351203700	膝控限位架组件	Knee control limit frame	1	1	1	1	1
	1350100900	油盘组件	Oil pan assembly	1	1	1	1	1
8	13501007	油盘	Oil reservoir	1	1	1	1	1
9	101511028	放油螺钉 SM5/16×24×7	Screw SM5/16×24×7	1	1	1	1	1
10	001047	放油螺钉垫圈	Washer	1	1	1	1	1
11	13523006	油盘垫	Gasket	1	1	1	1	1
12	13511006	膝控提升顶杆	Knee press lifter rod	1	1	1	1	1
13	10131001	磁块	Magnet	1	1	1	1	1
14	20131038	小油壶	Oil pot	1	1	1	1	1
15	10122060	机壳铰链	Rubber coat	2	2	2	2	2
16	1011203100	机壳铰链套	Hing	2	2	2	2	2
17	113522001	机头防震垫块 (大)	Cushion(big)	2	2	2	2	2
18	10122022	机头防震垫块 (小)	Cushion(small)	2	2	2	2	2
19	113511001	油袋(600ml)(10#)	Oil bag (600ml)(10#)	1	1	1	1	1
20	1383100300	线架组件	Spool stand complete	1	1	1	1	1
21	10111011	机头支柱	Frame support bar	1	1	1	1	1
22	1351203800	膝控操纵杆组件	Joystick assembly	1	1	1	1	1
22-1	13512038	膝控碰块弯杆	Bent rod	1	1	1	1	1
22-2	10112029	膝控碰块	Bell	1	1	1	1	1
22-3	10112030	碰块架	Bell bracket	1	1	1	1	1
22-4	101s12004	碰块架螺钉 M6×11	Screw M6×11	1	1	1	1	1
23	13502025	膝控铰链轴	Hinge pin	1	1	1	1	1
24	13527014	膝控复位弹簧	Spring	1	1	1	1	1
25	10101008	碰块弯杆接头	Connector	1	1	1	1	1
26	101s12003	螺钉 M8	Screw M8	2	2	2	2	2
27	10122024	碰块垫	Mat	1	1	1	1	1
28	H05010	开口挡圈	Split stop ring	1	1	1	1	1
29	11023001700	电控脚踏	Electric control pedal	1	1	1	1	1
	703725	包材	Packaging materials	1	1	1	1	1
30	11543100300	脚踏连杆	Pedal connecting rod	1	1	1	1	1
31	114712003	开口扳手(14-10)	Open wrench	1	1	1	1	1

11.新款自动抬压脚部件/Automtic presser foots parts

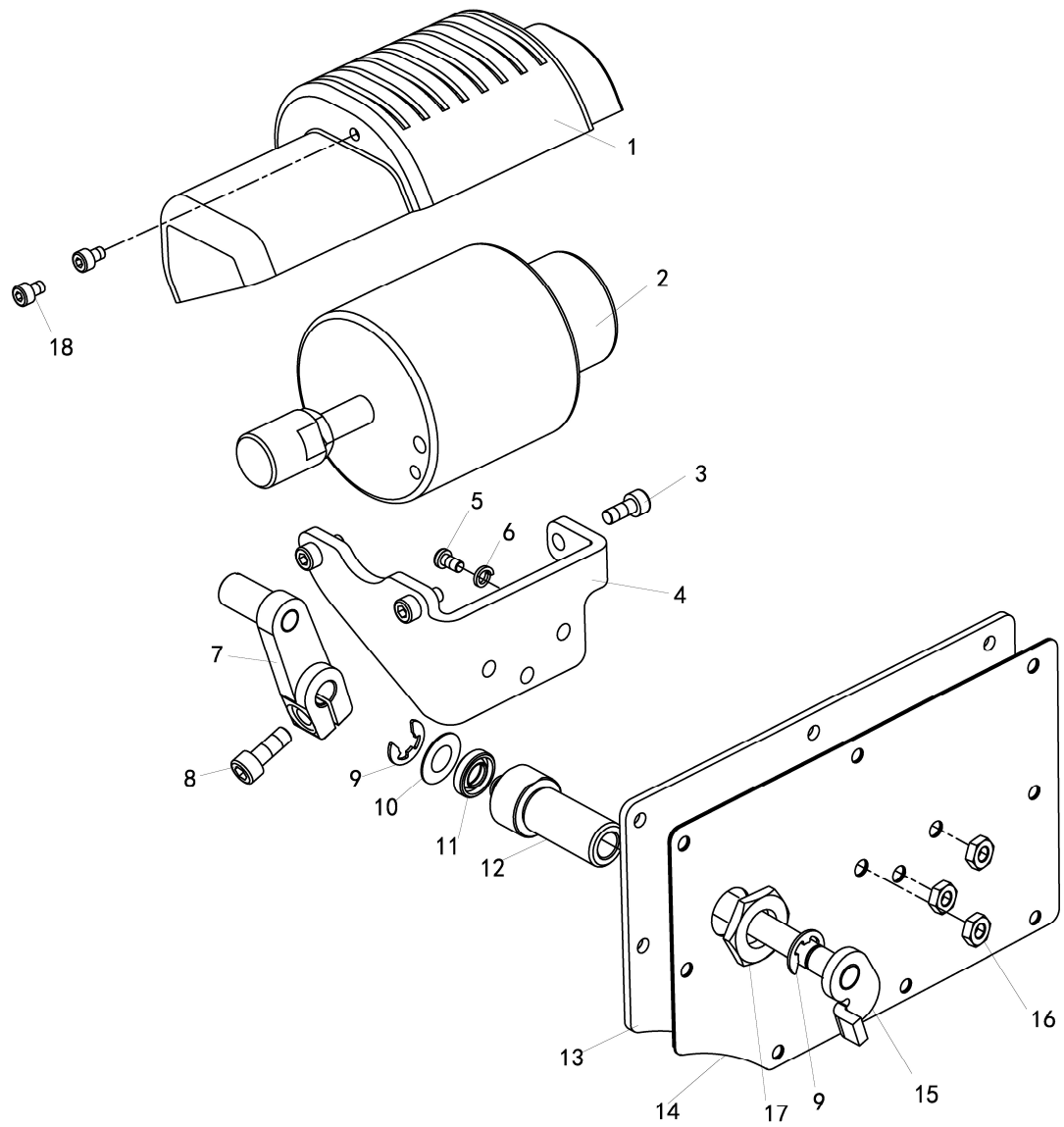

11.新款自动抬压脚部件/Automatic presser foots parts						
序号 NO.	公司件号 Part NO.	名称 PartName	零件描述 Description	数量 Number		
				-4	ZD-4	XB-4
1	114744001	电磁铁防护罩	Electromagnet shield	1	1	1
2	11473000400	抬压脚电磁铁组件	Lifting foot electromagnet assembly	1	1	1
3	S05005	螺钉 M5×12	Screw M5×12	3	3	3
4	114712006	电磁铁安装架	Electromagnet mount	1	1	1
5	207511026	螺钉 M6×16	Screw M6×16	3	3	3
6	W02004	M6 不锈钢弹垫	Spring washer M6	3	3	3
7	114704002	自动抬压脚曲柄	Automatic lifting foot crank assembly	1	1	1
8	207511026	曲柄锁紧螺钉 M6×16	Screw M6×16	1	1	1
9	H05001	开口挡圈	Retaining ring	2	2	2
10	12928004	轴向垫圈 A 1.2MM	Axial washer 1.2MM	1	1	1
11	30122039	压脚轴套油封	Oil seal	1	1	1
12	114703002	套筒	Sleeve	1	1	1
13	114712010	后窗板	Rear window	1	1	1
14	114722004	后窗板密封垫	Rear window gasket	1	1	1
15	11470200300	自动抬压脚轴组件	Automatic lifting foot crank	1	1	1
16	N01007	六角螺母 M6	Nut M6	1	1	1
17	112516011	套筒螺母 M16×1.5	Sleeve nut M16×1.5	1	1	1
18	421S11008	螺钉 M4×10	Screw M4×10	2	2	2

12. 气动抬压脚部件/Automatic presser foot parts

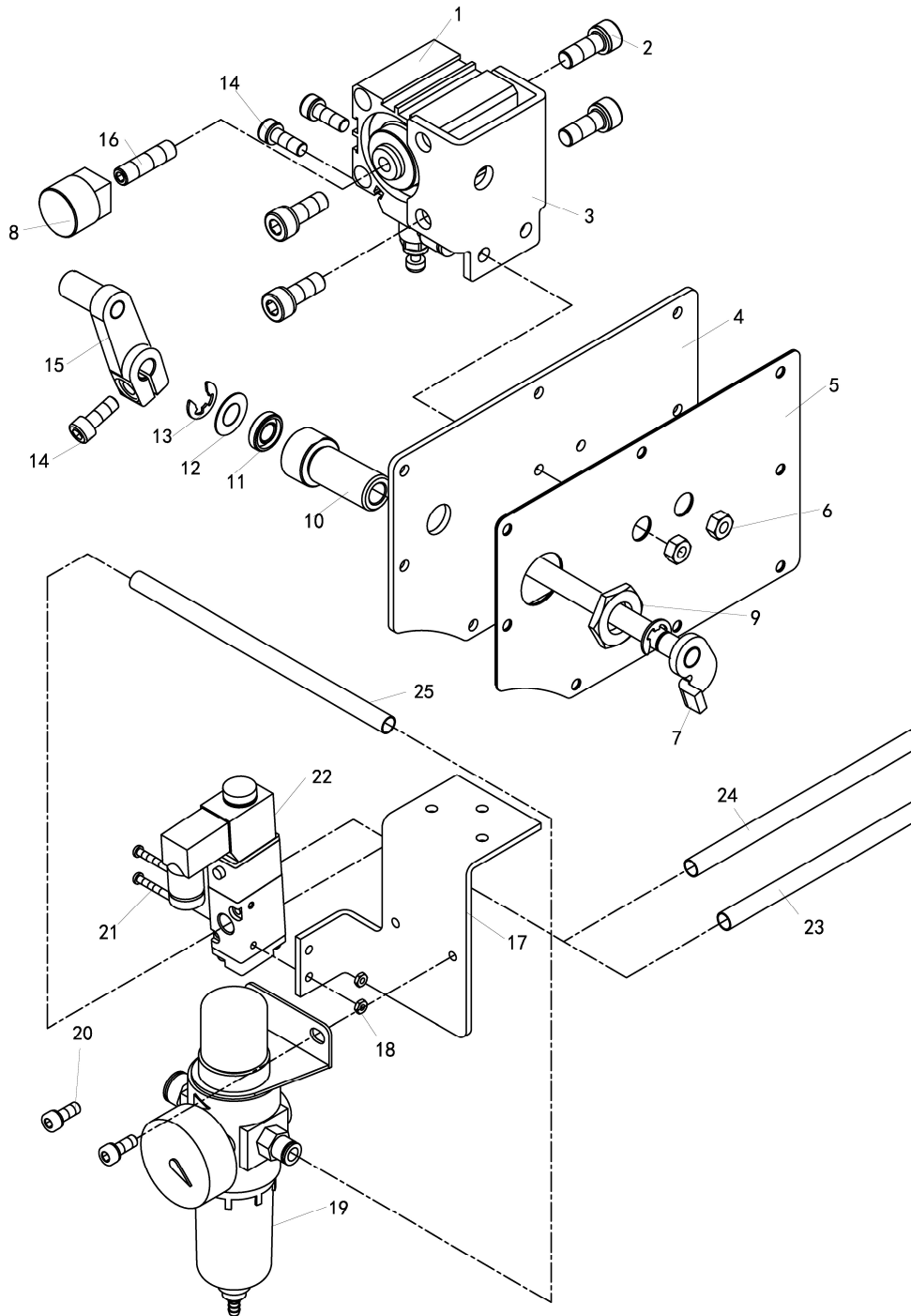

12.气动抬压脚部件/Automatic presser feet parts				
序号 NO.	公司件号 Part NO.	名称 PartName	零件描述 Description	数量 Number
				P-4
1	11474500200	抬压脚气缸组件	Lifting foot cylinder assembly	1
2	S05007	螺钉 M8x20	Screw M8x20	4
3	114712008	气缸安装支架	Cylinder mounting plate	1
4	114712009	后窗板(气动)	Rear window	1
5	114722003	后窗板密封垫片(气动)	Rear window gasket	1
6	N01007	六角螺母 M6	Nut M6	2
7	11470200300	自动抬压脚轴组件	Automatic lifting foot crank	1
8	121444003	C5-1923 抬压脚电磁铁接头	Lift foot electromagnet connection meaning	1
9	112516011	套筒螺母 M16x1.5	Sleeve nut M16x1.5	1
10	114703002	套筒	Sleeve	1
11	30122039	压脚轴套油封	Oil seal	1
12	12928004	轴向垫圈 A 1.2MM	Axial washer 1.2MM	1
13	H05001	开口挡圈	Retaining ring	3
14	207S11026	气缸安装架固定螺钉	Screw	1
15	114704002	自动抬压脚曲柄	Automatic lifting foot crank	2
16	1147N514001	内六角平端紧定螺钉	Screw	1
17	142312006	气压阀安装板	Valve mounting plate	1
18	N01013	GB/T6170-1986 螺母 M3(镀锌)	Nut M3	1
19	11424500400	气源处理元件	Gas source processing component	2
20	S05005	螺钉 M5x12	Screw M5x12	1
21	407S04053	十字半圆头螺钉 M3x25	Screw M3x25	2
22	11424500700	电磁阀	The electromagnetic valve	2
23		气管	Trachea	2
24		气管	Trachea	1
25		气管	Trachea	1

成套智联 让服装智造无限可能



杰克股份官方微信



杰克股份官方抖音



杰克资料库



参观杰克

400-8876-858
www.chinajack.com

杰克科技股份有限公司
浙江省台州市椒江区东海大道东段1008号
电话 :0086-576-88177788 88177789
传真 :0086-576-88177758

JACK TECHNOLOGY CO.,LTD
No.1008, Donghai Road East, Jiaojiang District,
Taizhou city, Zhejiang, China
TEL:0086-576-88177788 88177789
FAX:0086-576-88177758